

Iliffe Electrical Publications Ltd.,  
Dorset House, Stamford Street,  
London, S.E.1

**Managing Director:**

W. E. MILLER, M.A., M.I.E.R.E.

**Editor:**

F. L. DEVEREUX, B.Sc.

**Assistant Editors:**

H. W. BARNARD

T. E. IVALL

**Editorial**

D. C. ROLFE

G. B. SHORTER, B.Sc.

**Drawing Office:**

H. J. COOKE

**Production:**

D. R. BRAY

**Advertisements:**

G. BENTON ROWELL  
(Manager)

J. R. EYTON-JONES

Please address to Editor, Advertisement  
Manager or Publisher as appropriate

© Iliffe Electrical Publications  
Ltd., 1965. Permission in writing  
from the Editor must first be  
obtained before letterpress or  
illustrations are reproduced from  
this journal. Brief extracts or  
comments are allowed provided  
acknowledgement to the journal is  
given.

VOLUME 71 No. 2

PRICE: 3s 0d.

FIFTY-FOURTH YEAR  
OF PUBLICATION

# Wireless World

ELECTRONICS, TELEVISION, RADIO, AUDIO

## FEBRUARY 1965

- 57 Editorial Comment
- 58 Applications of Metal Oxide Silicon Transistors *By F. Butler*
- 61 H.F. Predictions—February
- 62 Electronic Laboratory Instrument Practice—2 *By T. D. Towers*
- 67 Recent Technical Developments
- 68 Transistor High-quality Audio Amplifier—2 *By J. Dinsdale*
- 77 Manufacturers' Products
- 82 NATO V.L.F. Station
- 84 Letters to the Editor
- 87 World of Wireless
- 89 Personalities
- 91 News from Industry
- 93 Further Notes on Signal Flow Diagrams *By W. Grant*
- 98 Microwave Circuit Design
- 99 Wide-range Transistor Wobbulator *By K. C. Johnson*
- 100 Commercial Literature
- 101 HF Communications *By G. Millington*
- 103 Point-to-Point Review—1964 *By D. Wilkinson*
- 104 Real and Imaginary *By "Vector"*
- 106 February Meetings

PUBLISHED MONTHLY (4th Monday of preceding month). Telephone: Waterloo 3333 (70 lines).  
Telegrams/Telex: Wivworld Iliffepres 25137 London. Cables: "Ethaworld, London, S.E.1."  
Annual Subscriptions: Home £2 6s 0d. Overseas £2 15s 0d. Canada and U.S.A. \$8.00. Second-class  
mail privileges authorised at New York N.Y. BRANCH OFFICES: BIRMINGHAM: King  
Edward House, New Street, 2. Telephone: Midland 7191. BRISTOL: 11, Marsh Street, 1.  
Telephone: Bristol 21491/2. COVENTRY: 8-10, Corporation Street. Telephone: Coventry  
25210. GLASGOW: 123, Hope Street, C.2. Telephone: Central 1265-6. MANCHESTER:  
260, Deansgate, 3. Telephone: Blackfriars 4412. NEW YORK OFFICE U.S.A.: 111,  
Broadway, 6. Telephone: Digby 9-1197.

**OFF**  
WITH THE FRONT PANEL

**ON** WITH

**PANORAMA**

**DIRECT VISION**

With the 'Panorama' direct vision picture tube it's freedom road all the way.

Freedom from multiple reflections, dust or condensed vapour: absolutely nothing gets between you and the picture because the 'Panorama' makes protective panels redundant. You're in touch with direct vision.

Freedom from tricky servicing: 4 conveniently positioned mounting lugs mean easy and independent mounting of the 'Panorama' tube.

Freedom from inconsistent picture quality: the 'Panorama' gives sharper brighter pictures—a fact further enhanced by the optimum performance of the latest Mullard electron gun.

Freedom from old-style design: the absence of a protective panel creates new styling opportunities for designers.

**Mullard** PANORAMA PICTURE TUBES

2WW-137 FOR FURTHER DETAILS.

MVM5809

# Wireless World

ELECTRONICS, TELEVISION, RADIO, AUDIO

## Mechanical Microwaves

IN last December's issue we looked at definitions of electronics and in January our contributor "Vector" dug deeper, penetrated the crust of old arguments and all but fell into the bottomless pit which awaits anyone who seeks to find where electronics starts and finishes. Having noted that "matter being what it is, every industry under the sun would qualify for an electronics label" he quickly climbed back onto the electrical plane and the comfort of familiar surroundings for the remainder of his disquisition.

This had taken him to the fringe of our subject where this month we propose to return to take another peep over the edge. Our passport to this frontier is valid: it is in fact microwaves which are now an indispensable tool for the investigation of the constitution of matter, particularly that of the solid state. The events which sufficiently stimulated our curiosity to make the journey were reports in the American literature (notably contributions by H. Matthews *et al.* in *Physical Review Letters*) that acoustical waves at frequencies of the order of 1000 Gc/s had been propagated in crystals.

Work on the propagation of acoustical (hypersonic) waves has been going on for nearly a decade but it is only during the past five years that techniques have been developed for extending the frequency range into the gigacycle region. Here we would emphasize that although these waves are excited and detected by electrical techniques they are independent elastic vibrations controlled by the masses of atoms and the restoring forces which give cohesion and define the solid state. Usually a film of piezoelectric or magnetostrictive material, half a wavelength thick, is applied to the end surface of a rod of the material under investigation, or, if it is itself an active material like quartz, the tip of the rod may be inserted into a re-entrant microwave cavity resonator.

Theory indicates that elastic vibration in solids is possible over a continuous spectrum of frequencies up to nearly  $10^{14}$  c/s (100,000 Gc/s). Below  $10^{12}$  c/s (1000 Gc/s) the wave velocity should be independent of frequency and wavelength, but above this the wavelength becomes comparable with inter-atomic distances and dispersion takes place, i.e. the energy in a wave at a single frequency is scattered into other modes determined by the crystal structure of the material. Peripheral electrons, as well as taking part in exchange forces between atoms have, as it were, a life of their own and can absorb and emit vibrational energy. They do so in a manner similar to that of the interaction of light with matter and the methods of quantum mechanics must be evoked to fit the facts. The elementary parcels of energy involved in extra-high-frequency elastic vibrations have been termed *phonons* to underline their similarity to photons.

Unfortunately we have no equivalent to the photoelectric cell for detecting phonons, and there is an interesting field here for further research. Some progress has been made, notably by N. S. Shiren, who has pointed out that in a paramagnetic material electromagnetic field energy (microwave photons) is absorbed in double quantum transitions with phonon absorption. At the upper limit of elastic vibration there are so many possibilities of interactions—with electron spin axes, with other phonons, etc.—that it is difficult to sustain coherent "monochromatic" vibration and there is rapid degeneration into a wide-band spectrum of frequency which can equally well be described as noise—or just heat. Investigators are also claiming the possibility of producing acoustical masers complete with "population inversion of energy levels" and parametric amplification of ultra-sound with "optical" pumping.

In a way we are back to the Victorian physics of "Heat, Light and Sound," but with the difference that whereas our fathers were taught these disciplines as separate subjects they are now seen to be one. And since mechanical elasticity, which is at the basis of sound in solids, is the result of exchange forces with electrons shared by adjacent atoms, and since light is emitted when electrons change their energy states, that one subject can fairly be claimed to be Electronics.

VOL 71 NO 2  
FEBRUARY 1965

# Applications of Metal Oxide Silicon Transistors

By F. BUTLER, O.B.E., B.Sc., M.I.E.E., M.I.E.R.E.

THE insulated-gate field-effect transistor (f.e.t.) is a solid-state device with characteristics closely resembling those of a thermionic tetrode. It fills a definite gap in the range of semiconductor products available today and its properties allow the designer to resurrect some thermionic valve techniques, with the advantage that there are no problems concerning heater supplies.

The Mullard company has developed a device of this kind which they call a Metal Oxide Silicon Transistor, and sample quantities of a type known as 95 BFY are available for evaluation. At present the cost is high, but within a year or two it should drop to a level low enough

Fig. 1. Graphical symbol and connections for Mullard 95 BFY metal oxide silicon transistor. Lead "z" is connected to the envelope and the substrate.

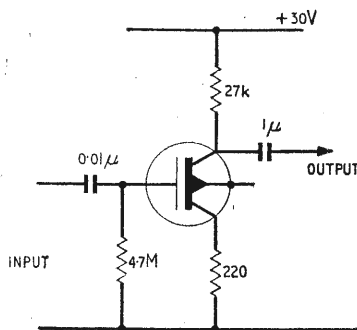
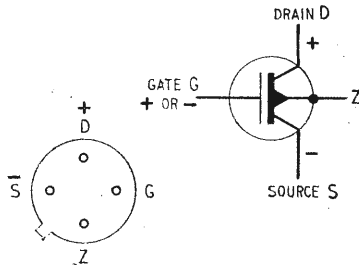

Fig. 2. Single-stage phase-reversing audio or video frequency amplifier.

to encourage widespread use. In anticipation of this, the following notes describe some applications for which the new unit is particularly suitable. Leaflets available from Mullard describe the main characteristics, and it is assumed that the reader has, or can get, a copy.

Fig. 1 shows the graphical symbol and the base connections. The gate corresponds to the grid of a valve, the drain to the anode and the source to the cathode. A fourth lead is connected to the semiconductor substrate and to the metal envelope of the transistor. It can be ignored in low-frequency applications. Presumably—though it does not say so on the data sheet—this lead could be earthed, and the device would then have to be operated from two separate power sources, one positive and one negative to ground.

The input resistance to the gate terminal is about one

million megohms which may justifiably be regarded as infinity. In practice, a bias resistor is required and this, ignoring certain feedback effects, will constitute the actual input impedance. It may be as high as 50 megohms.

## Low and Video-frequency Amplifiers

Fig. 2 shows an elementary example of the use of this transistor in a single stage phase-reversing amplifier of high input resistance and moderate voltage gain. Because of negative feedback developed across the 220-Ω resistance in the source lead the output impedance is almost equal to the load resistance for values of  $R_L$  up to about 30 kΩ.

Fig. 3 shows a bootstrapped version in which the input impedance is larger than the value of bias resistance actually used. These two circuits are ideally suited for direct coupling to a succeeding transistor stage in the common-emitter connection as shown in Fig. 4. Negative feedback serves to linearize the amplifier characteristic. The zener diode in the transistor emitter circuit allows a useful voltage drop across the 27-kΩ load resistance of the metal oxide transistor, while the 560-Ω resistance gives extra local feedback. The combination gives a power gain up to as much as 80 dB, the precise figure depending on the value of the input bias resistor. The gain and input resistance are in fact so high that self-oscillation can be induced merely by bringing the output lead back near the input circuit. Screening is required to prevent the pick-up of hum and noise by electrostatic means.

In view of the very high input impedance the amplifier noise figure is exceptionally low—much lower than could be attained by the use of conventional transistors, which perform well in this respect only when operating from sources having some prescribed (and often rather low) internal resistance. Not only is the noise level lower than usual but the noise power is differently distributed over the spectrum. In particular, the 1/f component seems to be absent or at least abnormally low, owing to the fundamentally different physical mode of operation of field-effect transistors. Moreover, the load resistance of the f.e.t. may be set equal to the optimum source resistance required for low-noise operation of a succeeding transistor amplifier stage. This ensures that the noise contribution from the second stage does not significantly increase the overall noise figure of the amplifier pair.

The f.e.t. followed by a directly-coupled transistor stage makes a useful preamplifier for use in measuring equipment or for coupling to a high-impedance transducer. For example, a pair of these preamplifiers would be ideal for use in a phasemeter of the type described by the writer in the September 1964 issue of *W.W.* The f.e.t. amplifier is equally useful as the input stage of a millivoltmeter, as the resonance indicator of a

Q-meter or in an absorption-type frequency meter where the high input resistance and low capacitance are particularly valuable.

Still more gain and a much reduced output impedance can be secured by adding a third stage to the amplifier shown in Fig. 4. Because of the comparatively high supply voltage required by the f.e.t. it is convenient to connect the extra transistor in series with the output stage of Fig. 4. A suitable arrangement is shown in Fig. 5. In this  $Q_1$  and  $Q_2$  function as already described, while  $Q_3$  acts as a bootstrapped emitter-follower in series with  $Q_2$ . It behaves like a very high-impedance load, and at the same time an output is available at low impedance from its emitter terminal. Any small change in the emitter current due to an input signal causes a change in the voltage drop across the 560- $\Omega$  load resistance. There is a change of base current into  $Q_3$  in such a sense as to oppose the original current change.

Negative feedback is taken to  $Q_1$  through the 10-k $\Omega$  and 560- $\Omega$  resistors which form a potential divider across the output terminals. Apart from the input and output capacitors, the amplifier is d.c.-coupled throughout.

With a 30-V supply battery the output is 6 V r.m.s.—much larger than usual for a transistor amplifier. Some selection of components may be required to maximize the undistorted output. Normally it is sufficient to alter the 56-k $\Omega$  load resistance of the f.e.t. while observing the output waveform on an oscilloscope until symmetrical clipping occurs at the overload point. The remaining components may be left unchanged.

The input impedance at low frequencies is about 10 M $\Omega$ . Even when operated with an external series

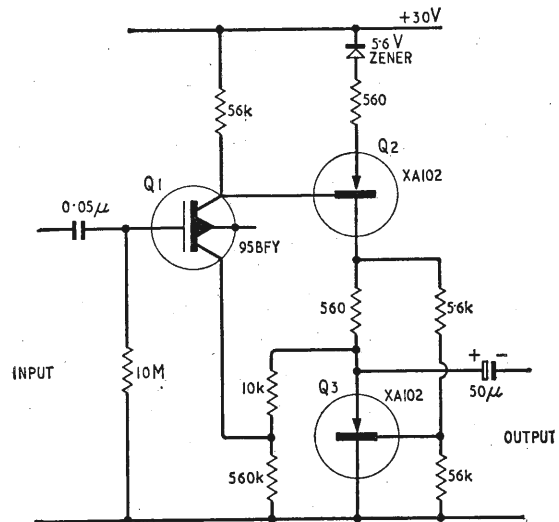

Fig. 5. Three-stage amplifier of low output impedance.

resistance of 5 M $\Omega$ , the gain is well maintained up to 1000 c/s or more. Because of input capacitance, some equalization is required in order to obtain uniform response up to high audio or low video frequencies. The characteristic is, of course, much flatter if the amplifier is driven from a constant-voltage source, since in this case the input capacitance is immaterial.

Rough tests show that the output at 100 kc/s is less than 3 dB down on the low frequency gain when the amplifier is fed from a low-impedance source.

## Oscillators

Designing r.f. tuned-circuit transistor oscillators of good performance is not particularly difficult, and the cost of field-effect devices can only be justified in special cases where, for example, extreme stability is required. The f.e.t. will maintain strong oscillation with very loose coupling to the tuned circuit, so that the properties of the oscillator become virtually those of the resonant circuit alone. Amplitude limiting is easily applied, and because the metal oxide transistor is of the silicon type operation is feasible over wide temperature ranges.

There are some difficult oscillator problems which can be neatly and simply solved by the use of field-effect transistors, and two illustrative examples will now be discussed. The first is a low-frequency crystal oscillator using flexural-mode quartz bars or rings.<sup>1</sup> These are characterized by the extremely high values of the elements composing the equivalent electrical circuit of the quartz vibrator. For example, a 1000-c/s gapped ring may have a series arm of about 10 megahenries, 1 megohm and 0.002 pF, the whole being shunted by a static capacitance of 10 pF. Such crystals are normally provided with divided (plated or sputtered) electrodes brought out to three terminals. In his paper, already quoted, J. E. Thwaites shows that the equivalent circuit may be reduced to that shown in Fig. 6. At the series resonance frequency of the crystal this reduces to a high resistance (four times the series resistance), followed by a 1:1 phase reversing transformer. The input terminals of the network and the primary terminals of the

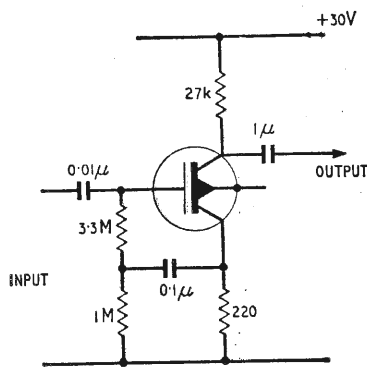

Fig. 3. Bootstrapped version of Fig. 2 amplifier.

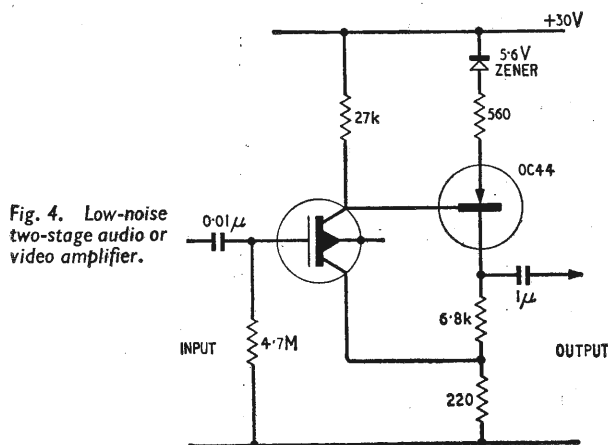

Fig. 4. Low-noise two-stage audio or video amplifier.



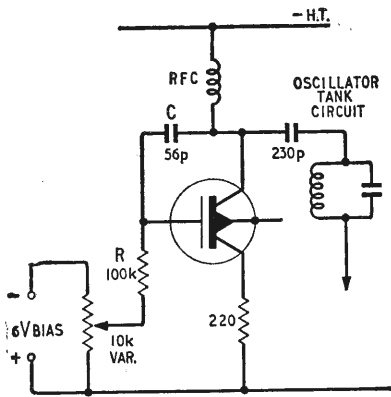

Fig. 9. Voltage-controlled oscillator or reactance modulator. The r.f.c. and the -h.t. connection may be removed.

gate and drain of the f.e.t., and a resistance R, which includes a part of the bias potentiometer, is connected between gate and ground. The combination is equivalent to a capacitance  $g_m RC$  where  $g_m$  is the dynamic mutual conductance of the f.e.t. at the selected bias voltage. If  $g_m = 2 \text{ mA/V}$ ,  $R = 100 \text{ k}\Omega$  and  $C = 50 \text{ pF}$ , the injected capacitance is  $10,000 \text{ pF}$ , a value which would cause a large frequency change of the oscillator to which the modulator is connected. In practice the reactance of the feedback capacitor should be at least five times the value of the associated resistor and this consideration limits the maximum excursion of oscillator frequency.

A remarkable feature of Fig. 9, and one which calls for fuller investigation, is that the r.f. choke may be removed and the h.t. supply disconnected from the f.e.t. without affecting the ability to control the oscillator frequency by changing the bias on the f.e.t. Presumably this transistor is acting as a shunt-fed rectifier coupled to the r.f. oscillator, thereby generating its own h.t. voltage. The blocking capacitor shown ( $230 \text{ pF}$ ) limits the total change of capacitance across the oscillator. It is essential to use this if the f.e.t. is operated without

an h.t. connection, which tends to support the rectification theory just mentioned. The capacitor must not be too large or intermittent oscillation (squegging) may take place.

Experiments with the circuit of Fig. 9 show that when this is coupled to an oscillator at  $100 \text{ kc/s}$ , bias changes of the f.e.t. from  $-6 \text{ V}$  to zero, or rather to the voltage drop due to drain current flowing in the  $220\text{-ohm}$  resistor, are sufficient to swing the frequency from  $90$  to  $70 \text{ kc/s}$ . The limits depend on the L/C ratio of the oscillator as well as on the modulator parameters.

The effect was observed on low frequencies so that the oscillator waveform could be simply checked on an oscilloscope. Over the whole range of frequency, the amplitude change was less than  $3 \text{ dB}$ .

Fairly obvious modifications of the basic circuit will convert it into an a.f.c. system or to a voltage-controlled oscillator of high sensitivity. Other uses, e.g. in a phase-lock loop, will suggest themselves to the reader.

### Conclusion

Several other circuits have been built and tested. Their performance is on a par with conventional transistor structures but not sufficiently outstanding to justify the extra cost of f.e.t. devices.

There are many other applications for which metal oxide transistors appear to be well suited, e.g. in operational amplifiers, balanced modulators, waveform generators, logic circuits and in control and regulator systems. These are in addition to their obvious uses in radio receivers, tape recorders, oscilloscopes, parametric amplifiers and frequency dividers. It is hoped that these notes will stimulate interest in the possibilities of this intriguing new member of the solid-state family.

### REFERENCE

1. J. E. Thwaites, "Quartz Vibrators for Audio Frequencies," *Proc. I.E.E.*, Vol. 99, Part IV, 1952 (also Monograph No. 21, 15th January, 1952).

## H. F. PREDICTIONS — FEBRUARY

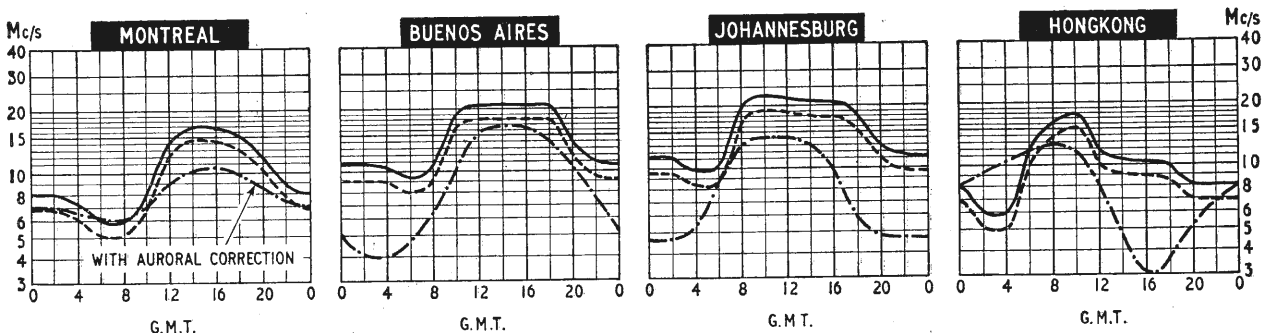

The prediction curves show the median standard MUF, optimum traffic frequency and the lowest usable frequency (LUF) for reception in this country. Unlike the standard MUF, the LUF is closely dependent upon such factors as transmitter power, aerials, and the type of modulation. The LUF curves shown are those drawn by Cable & Wireless Ltd. for commercial telegraphy and assume the use of transmitter power of several kilowatts and rhombic type aerials.

The Zurich sunspot number predicted for December was 6

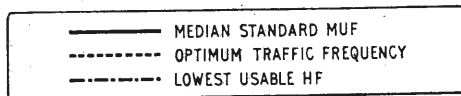

but it was actually 14. The revised predicted numbers for January to June inclusive, i.e. 8, 8, 9, 10, 11, 12, respectively, suggest that the sunspot minimum has past. A steady rise would now be expected over the next few years.

# ELECTRONIC LABORATORY INSTRUMENT

## 2—MEASURING DIRECT CURRENT AND VOLTAGE

**T**HERE are three common types of instruments for taking d.c. measurements; electrical meters, valve voltmeters and digital voltmeters. The first type are really non-electronic and should not fall into the ambit of this series, but so many d.c. measurements are made with such meters that we must devote space to them.

Up to World War II, most laboratory d.c. measurements were made with simple electrical meters. Since then, electronics has become so complex that instruments have had to improve greatly in accuracy, range, concept and convenience. Because of this, the simple electrical meter or multimeter is being superseded by the electronic meter (valve voltmeter or v.v.m.) which is in turn being ousted by the digital voltmeter (d.v.m.). If you are going to work efficiently in electronics you must have some knowledge of all three basic groups—meters, v.v.ms and d.v.ms.

### Electrical D.C. Meters

Most electrical meters, even when called voltmeters, actually measure current. On the other hand, most valve voltmeters (i.e. meters aided by in-built amplifiers) primarily measure voltage, as do digital voltmeters. However, we treat current and voltage meters together here because there is no essential difference between them. You will find that you can in most cases, with a little ingenuity, analyse a voltage reading as a measurement of current through a resistance and a current as a voltage across a resistance.

Instrumentation text-books discuss many types of basic electrical meters such as moving-coil, dynamometer, moving-iron, electrostatic. In normal labs, the meter you use will be a moving-coil one in 999 cases out of

1,000, and we will consider only this type here. We need not bother too much with the constructional design details of the meter, except to note that the needle deflection is proportional to the amount of *d.c. current* fed into the instrument to pass through a moving coil suspended in the field of a permanent magnet. The moving-coil meter is therefore basically a d.c. *current* meter. It can, however, be adapted to measure a d.c. voltage, *V*, by applying the voltage to a known resistance,  $R_s$ , in series with the meter (of known resistance  $R_m$ ). We then arrive at the voltage from the measured current *I* and Ohm's law,  $V=I(R_s+R_m)$ .

Meters fall into two classes according to the limits of their errors. In broad general terms these are "precision" meters with errors between 0.3 and 0.5% of full scale deflection (f.s.d.), and "industrial" with errors of between 0.75 and 3.0%. Most laboratory meters fall in the second category. This is because they have to be portable (and thus robust) and cheap. "Precision" meters usually require a very delicate coil suspension, and they are not normally suited to "knocking about the bench"—if they are to maintain their precision. Recent developments in the way of pivotless taut-band suspension has made more robust "precision" meters possible, but for most run-of-the-mill measurements the 3% of the "industrial" meter is adequate.

Do not confuse precision with sensitivity. Portable "industrial" meters are now obtainable down to  $10\ \mu\text{A}$  f.s.d. and partially portable versions down to below  $1\ \mu\text{A}$  f.s.d. The range limit is determined by the torque-to-weight ratio. Torque can be reduced by unipivot or taut-band construction and weight by a "light-beam" pointer. Non-portable free-suspension galvanometers using a beam of light indicator can have a full-scale

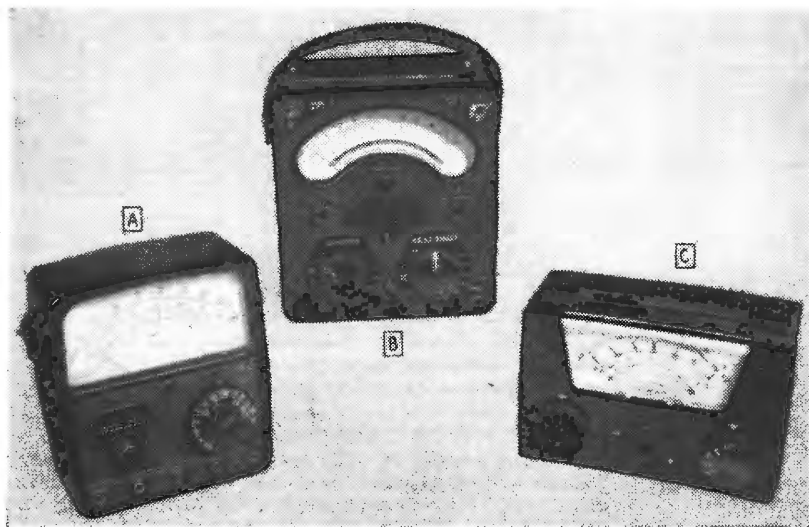

Fig. 7. Multimeters, General-purpose. Typical electrical (i.e. non-electronic) instruments commonly used for routine d.c. measurements of current and voltage. (A) Taylor 77A; (B) Avo Model 8; (C) Philips P817.00.



# PRACTICE

By T. D. TOWERS,\* M.B.E., A.M.I.E.E., A.M.I.E.R.E.

deflection of  $1\mu\text{A}$  on a 6 in scale. Recent advances have produced semiportable ultrasensitive d.c. current meters with f.s.d.s as low as  $0.2\mu\text{A}$ .

When using a d.c. meter, you should have some idea of the approximate resistance value of the basic meter movement. This depends on the f.s.d. current, and can vary between makes, but for typical general-purpose laboratory meters a useful rule of thumb is that the resistance in ohms can be taken as approximately 100,000 divided by the f.s.d. in  $\mu\text{A}$  in the most sensitive range. For example a  $10\mu\text{A}$  meter will have a resistance of about  $10\text{k}\Omega$ . This means that the voltage drop across the average laboratory meter movement is about 100 mV. Differences from this may arise from the effect of the "swamping" series resistor that is generally included in the basic meter movement to provide temperature compensation.

A traditional way to specify voltmeter sensitivity has been as so many "ohms-per-volt," but nowadays it is more common to specify the current for full-scale deflection in the most sensitive range. This comes to the same thing, because the meter resistance  $R_M$ , the f.s.d. current  $I$ , and the f.s.d. voltage  $V$  are related by  $I=V/R_M$ . Thus a 20,000 ohms-per-volt movement is equivalent to a  $1/20,000\text{ A}=50\mu\text{A}$  movement.

It scarcely needs pointing out how a basic d.c. current meter is made to act as a multirange current-voltage meter of the general purpose lab. type. A moving-coil movement of say  $50\mu\text{A}$  f.s.d. is shunted by switched parallel resistors in the higher current ranges, and padded out by series resistors in the voltage ranges. The main practical importance of this is the warning *never* to apply a voltage to a meter when switched to a current range because a destructively high current can pass through the low-resistance coil and damage the movement or bend the needle.

Meters used for d.c. measurements in laboratories are mostly multirange instruments which, by means of rotary switches on the front panel, measure a wide range of current and voltage. Very often, too, they have provision for a.c. and resistance measurements. Fig. 7 shows a selection of typical multimeters. The AVO-8 (B in the illustration) is a world-wide multimeter "workhorse." Even as far away as Russia, engineers call a multimeter an "AHVO" (written ABO in their script). Other multimeters in common use include Taylor and Philips (examples illustrated), and instruments from Salford Instruments and Sangamo Weston. The Daystrom (Heathkit) MM1U, which can be obtained in kit or assembled form, is also popular.

Multimeters can cope easily with the highest d.c. voltages and currents met with in a normal electronics laboratory, but they have limitations in the low-level field. The limits of sensitivity for truly portable multimeters are about  $50\mu\text{A}$  and 1 V f.s.d. but some ultrasensitive meters such as the Taylor 127A go down to

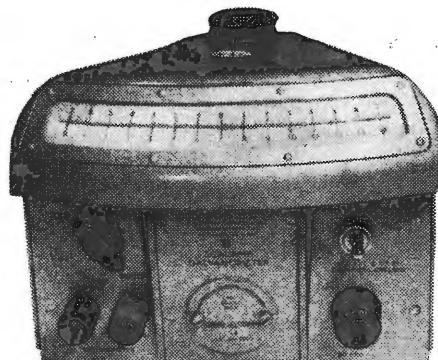

Fig. 8. Galvanometer-type D.C. Meter, Special-purpose. Typical ultra-sensitive non-electronic instrument for refined d.c. measurements (W. G. Pye "Scalamp" galvanometer type 7901/S).

$10\mu\text{A}$  and 100 mV f.s.d. However, this is as far as "straight" non-electric portable meters go.

Multimeters are all right for uncritical d.c. measurements around the lab. They tend to become inaccurate when you try to measure below about 100 mV or  $5\mu\text{A}$ . For accurate low-level d.c. measurements, you must turn to more sophisticated instruments. There are three main categories of these, each with its own special advantages: (a) ultra-sensitive galvanometer-type meters, (b) amplifier-aided meters, (c) digital voltmeters.

## Ultra-Sensitive D.C. Electrical Meters (Galvanometers)

You can increase the sensitivity of a meter by lightening the pivot movement. This gives rise to the "galvo" type instrument of which a typical good example by W. G. Pye is shown in Fig. 8. Other names in the galvanometer field are Baldwin Industrial Controls, Cambridge Instruments, Dobbie McInnes, Evans Electro Selenium, S.E. Labs, and Weston.

The main drawbacks of the galvo are its susceptibility to damage by shock and its low input resistance (typically 25-1500 ohms). Scale deflection for  $100\mu\text{V}$  varies typically from  $\frac{1}{2}$  in to 5 in. As a low-impedance device, however, the galvo is really more suited to measuring small currents; typical sensitivities are deflections of  $\frac{1}{2}$  in to 10 in for  $1\mu\text{A}$ . Recent designs have improved the "handlability" of the galvo, but for robust ordinary lab. use most engineers nowadays turn to some form of amplifier-aided meter. These fall into two categories: analogue and digital, each with its special features.

## Valve Voltmeters

The general-purpose v.v.m., of which a few typical examples are shown in Fig. 9, has tended to oust the multimeter for uncritical measurements. It can do all the work of a multimeter and in addition has a very high input impedance (of the order of 1 to  $10\text{M}\Omega$  in the most sensitive voltage range), as compared with conventional multimeters (at best  $100\text{k}\Omega$ ). The v.v.m. thus disturbs the circuit being measured much less than the multimeter does.

The general-purpose v.v.m. has its limitations, however. The cheaper ones have a full-scale deflection of only about 1 V in the most sensitive range although

\*Newmarket Transistors Ltd.

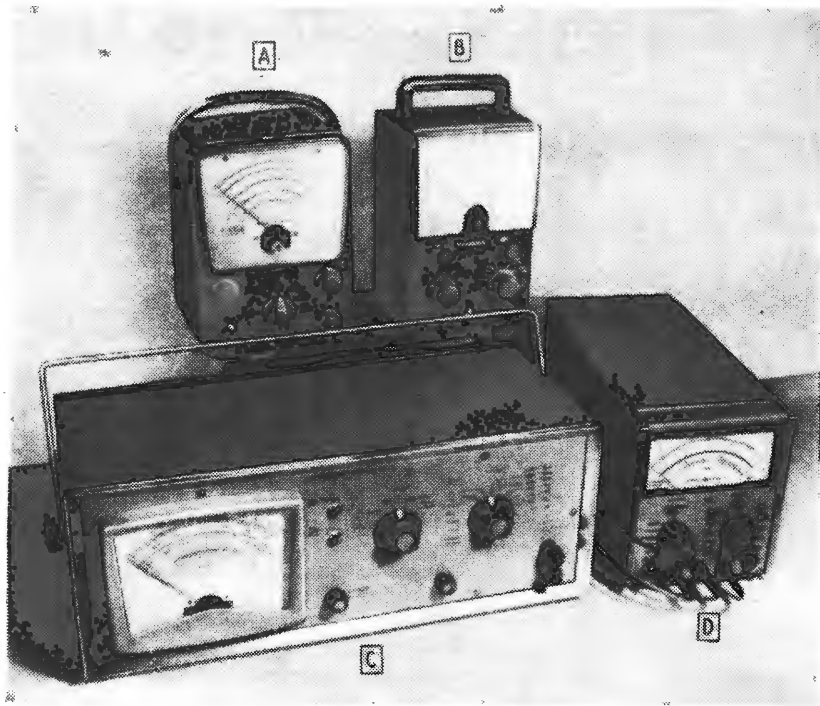

Fig. 9. Valve-voltmeters, General-purpose. Typical amplifier-aided instruments used for routine d.c. measurements. (A) KLB "Paco" V70; (B) Heathkit V7A; (C) Avo H.I. 108 transistorized; (D) Hewlett-Packard 410C.

better units go down to 100 mV f.s.d. As a result, run-of-the-mill v.v.ms are not really suited to accurate measurements of voltage below about 100 mV.

Until recently, too, they generally used valves and were "tied to the mains." But transistorized versions such as the AVO HI-108 at C in Fig. 9 make it possible to operate them from batteries, so that they now achieve the portability of the multimeter (which of course does not require a power supply for d.c. measurements).

Although the v.v.m. is essentially a voltage measuring device, general-purpose instruments often include internal resistances by which current measurement can be made by measuring the voltage drop across the resistance.

The v.v.m. has two main advantages over the multimeter. It measures voltages in high resistance circuits

much more accurately and the internal linear amplifier provides a simple overload protection circuit because the amplifier stages "limit" or "bottom" under an overload and do not pass it on to the delicate meter movement. (It should be pointed out, however, that the better multimeters do have meter overload protection circuits.)

Some names in general-purpose valve voltmeters (apart from KLB, Avo, Heathkit and Hewlett Packard illustrated in Fig. 9) are Airmec, Furzehill, Philips, Salford and Taylor.

### Special-Purpose Valve Voltmeters

More sophisticated v.v.ms are available for d.c. measurements in the millivolt (or microvolt) and microamp (or

Fig. 10. Valve-voltmeters, Special-purpose. Typical ultra-sensitive valve-voltmeters in common use for refined precise d.c. measurements. (A) Philips GM6020 microvoltmeter; (B) W. G. Pye 11360 nanoammeter; (C) Ekco Electronics N616A vibrating-reed electrometer; (D) Hewlett-Packard 425A microvoltmeter.

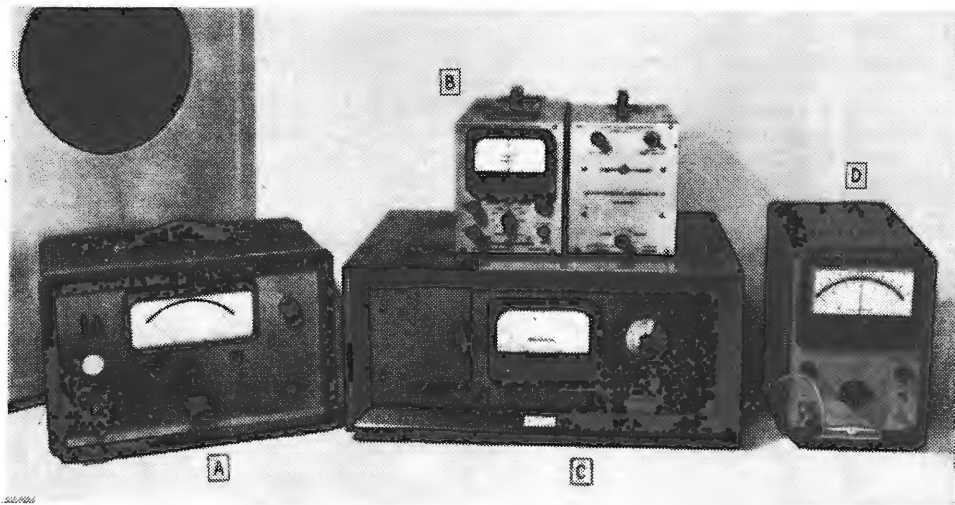



Fig. 11. Digital Voltmeters. Typical electronic digital instruments becoming widely used for routine and special precision d.c. measurements. (A) Wayne-Kerr "Digitec" Z-1202-B; (B) Digital Measurements DM2022.

nanoamp=millimicroamp) regions. Fig. 10 shows some commercial examples of these instruments.

Two main problems exist for very refined v.v.ms: so called "grid-current leakage" and "zero-drift". For very low current measurements, the grid-current of the input valve becomes significant compared with the current being measured. Special "electrometer" valves running at low anode volts and having grid currents about a hundred times down on a conventional valve have been designed to meet this problem. With such electrometer instruments, currents down to fractions of a nanoamp can be measured accurately, as can voltages in the  $\mu\text{V}$  region. Typical of such is the Philips GM6020 ( $100 \mu\text{V}/100 \mu\text{A}$  f.s.d.) shown in Fig. 10. Of the other instruments shown, the W.G. Pye 11360 provides down to  $10 \mu\text{V}/10 \mu\text{A}$  f.s.d.; the Ekco N616A measures currents in the range  $10^{-8}$  to  $10^{-11}$  A from high-impedance sources such as ionization gauges; the Hewlett-Packard 425A has a  $10 \mu\text{V}/10 \mu\text{A}$  f.s.d. range.

Apart from the four companies mentioned above, other firms in the special-purpose v.v.m. field are Airmec,

Avo, Cambridge Instruments, Dawe, E.I.L. Kasama, Marconi, McMurdo, Thomas Industrial.

At first it might seem that there would be few normal lab. requirements for such refined instruments. But in the past five years there has been a quiet revolution in electronic circuitry that is steadily bringing them on to the lab. benches for general-purpose use. This is the advent of v.h.f. diffused silicon transistors, field effect transistors, and thin film circuits. These new-generation devices are characterized by leakage currents three orders of magnitude less than those of germanium components. Germanium devices with leakage currents much less than a microamp are unusual, but in the years to come general-purpose silicon devices with leakage currents substantially less than a nanoamp will be commonplace. The f.e.t. is a typical example of this, where its input impedance can be many tens of megohms. The only way to test such devices satisfactorily is to have lab. equipment capable of measuring these ultra-low currents and voltages.

### Digital Voltmeters

Another approach to the measurement of extremely low d.c. currents and voltages is the digital voltmeter. This works by comparing the unknown voltage with an internal voltage reference and displaying the reading in number form. The d.v.m. has five advantages over the other types of instruments discussed so far. First, it gives the convenience of a numerical readout, which does not have to be carefully interpreted as in a pointer instrument. Secondly, its readout is such that the readings can easily be printed out automatically. Thirdly, it is capable of extreme accuracy because it is always working against an inbuilt standard. Fourthly, it is capable of a sensitivity almost as high as that of a special purpose valvevoltmeter. Fifthly, its error is constant for all readings (not like an analogue meter where the relative error, specified in terms of full scale deflection, increases as the needle goes down the scale).

For all these reasons, d.v.ms are tending to oust both d.c. meters and amplifier-aided meters. They are extremely robust now that, in general, they are transistorized, and they are available from fairly simple limited-performance units up to highly complex sophisticated versions. They find very wide use as the "electronic heart" of data logging systems.

Two typical commercial d.v.ms are illustrated in Fig.

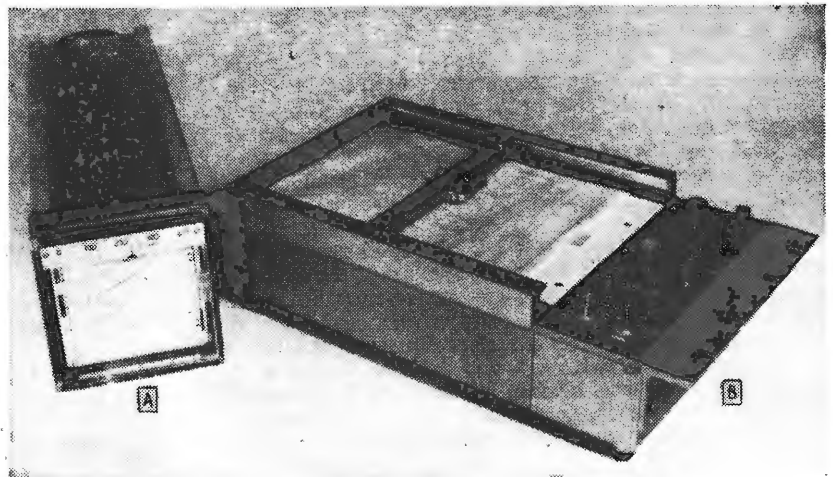

Fig. 12. Recording Instruments for D.C. Measurements. Typical examples of strip chart and XY recorders. (A) Philips PR2400A strip recorder; (B) Hewlett-Packard "Moseley" 135A XY autoplottedter.



Fig. 13. Precision Standard D.C.-Measurement Instruments. Typical examples of instruments used for reference purposes: (A) Avo "Precision Meter"; (B) W. G. Pye 7569/P portable potentiometer.

11. Models at present commercially available vary in size from the miniature Digitec of Wayne-Kerr (at A) up to the Digital Measurements DM2022 (at B). Micro-miniature circuitry now being developed points to the d.v.m. of the future being no larger than an Avo and equally portable.

Many companies apart from the two mentioned now market d.v.m.s, including Electronic Associates, Ferranti, Gloster, Hewlett-Packard, International Electronics, Racal, Research Electronics, Roband, Scientific Furnishings, Solartron, Southern Instruments.

### Recording Instruments for Measuring D.C.

While digital voltmeters can be used to print out readings, there is often a lab. requirement for some continuous recording measurement of d.c. parameters. These fall into two categories: instruments for measuring d.c. voltage or current as a function of time (i.e., strip or chart recorders), and instruments for measuring two d.c. values against one another (i.e., XY plotters). In Fig. 12 are shown two typical examples.

The Philips strip recorder type PR2400A at A is typical of chart recording instruments, which are available commercially from such firms as Advance, Beckman, Bryans, Cambridge Instruments, Everett Edgumbe, Evershed and Vignoles, George Kent, Graphic Instrument Research, Hewlett-Packard, International Electronics, Smiths, Southern Instruments and West (Rustrak).

The Hewlett-Packard 135A XY plotter illustrated also at B in Fig. 12 is again a typical example of the type of instrument for recording two d.c. measurements against one another. XY plotters are commercially available also from such firms as Advance, Bryans, International Electronics, Scientific Furnishings, and Smiths. In my own field of transistor engineering, XY plotters find a good use in drawing the characteristic curves of a transistor, e.g., the variation of collector leakage current against collector voltage.

### Precision D.C. Measurement Standard Instruments

In an electronics laboratory you must hold some form of standard against which to check d.c. measuring equipment. Fig. 13 illustrates two good examples of this type of reference instrument. The first (A) is the Avo precision d.c. current meter which is used merely by placing it in series with the meter to be checked and passing the same current through both, or placing it in parallel with a voltage meter to check voltage readings. Other widely used precision reference d.c. meters are the Weston S66, and Cambridge Instruments Pattern T laboratory standards.

The other common lab. d.c. reference instrument met with is the d.c. potentiometer, of which a typical example, the W.G. Pye 7569/P, is illustrated also in Fig. 13. This has its own inbuilt taut-suspension galvo null-detector. By means of this and an accurate internal potentiometer the value of voltages down to tens of microvolts can be read off accurately and compared with the voltage reading on the meter to be tested. Many other companies market d.c. potentiometers, but they are too numerous to list here.

### Practical Aspects of D.C. Measurements

So far we have considered largely *which* instrument you use to measure *what*. It would not be out of place now to record some practical advice on how to use d.c. measuring instruments—here is my list of do's and don'ts.

- (1) *Do* select correct instruments for measurements.
- (2) *Do* study instrument handbooks. (Have you looked on the back of an Avo?)
- (3) *Do* use meter in position recommended by maker.
- (4) *Do* remember that a meter can read differently standing up and on its back.
- (5) *Do* check and adjust zero reading regularly.
- (6) *Don't* switch straight on to the expected range but start in a higher range and work down.
- (7) *Do* check and *double check* range selected before starting to measure.
- (8) *Do* select finally the range where the reading comes above  $\frac{1}{2}$  full-scale.
- (9) *Don't* blindly trust what you see on the meter.
- (10) *Do* cross check the reading (even if only by thinking "Is this sensible?").
- (11) *Do* estimate the error caused by instrument loading of the circuit.
- (12) *Don't* read a 3% meter to three decimal places.
- (13) *Don't* try to test voltage with a meter switched to a current range.
- (14) *Do* always switch a multimeter to its highest a.c. voltage range after use.
- (15) *Do* let valved electronic instruments "warm up" before making precise measurements.
- (16) *Do* hold probes carefully (leakage across your fingers can vitiate low level measurements—and be unpleasant or dangerous at high levels!).
- (17) *Don't* bump a meter (treat it like an egg).
- (18) *Do* (until recalibrated) label an instrument that has had a shock.
- (19) *Don't* try to repair an instrument yourself: leave it to the experts.
- (20) *Don't* unintelligently believe instruments hold their calibration indefinitely.
- (21) *Do* have meters calibrated regularly.
- (22) *Do* short-circuit the terminals of a sensitive meter after use.
- (23) *Do* keep out dust (by covering when not in use).

# RECENT TECHNICAL DEVELOPMENTS

## Gallium Phosphide Diode Light Modulator

Modulation of light by electroluminescent semiconductor diodes, usually gallium arsenide, has been known for some time (*Wireless World*, August, 1963, p. 370, August, 1964, p. 377). In *Applied Physics Letters* (October 1) it is reported that Bell Telephone Laboratories have demonstrated light modulation, from an external source, using gallium phosphide diodes.

Modulation of light emitting diodes (laser type) has been achieved by various methods, for instance by variation of forward bias, by electro- or magneto-optic effects, by direct variation of energy levels or by variation of laser resonance characteristics. The gallium phosphide modulator uses the electro-optic effect in which piezoelectric crystals become birefringent (Pockles effect, akin to the Kerr effect). The two resultant polarized components travel at different velocities and a variation in velocity due to the field gives a phase modulation which can be converted to amplitude modulation by passing the light through an output polarizer or analyzer. A reverse bias is applied across the p-n junction and light, e.g. from a laser, is directed down the junction and confined to the junction region due to discontinuities in refractive index at the junction boundary.

With 31 volts across the junction a phase difference of  $140^\circ$  was recorded (at  $5460 \text{ \AA}$ ) suggesting that 88% of the light can be amplitude modulated. The diode operates at room temperature.

## Freehand Graphical Input for Digital Equipment

A system designed to convert freehand graphical information on a real-time basis into digital form which can then be stored, was described in a note by P. W. Woo published in *IEEE Transactions on Electronic Computers* October 1964. The stored information can be displayed using a c.r.t. projection system and, in particular, on to the drawing board, enabling the designer to see his drawing.

Several devices exist for such analogue-to-digital conversion but the system described (see Fig. 1) overcomes most of their drawbacks. Ultrasonic vibrations are transmitted periodically and alternately from x- and y- transducers mounted along the edges of a glass tablet and are received by a pen transducer. The time delay between transmission of a pulse and its reception

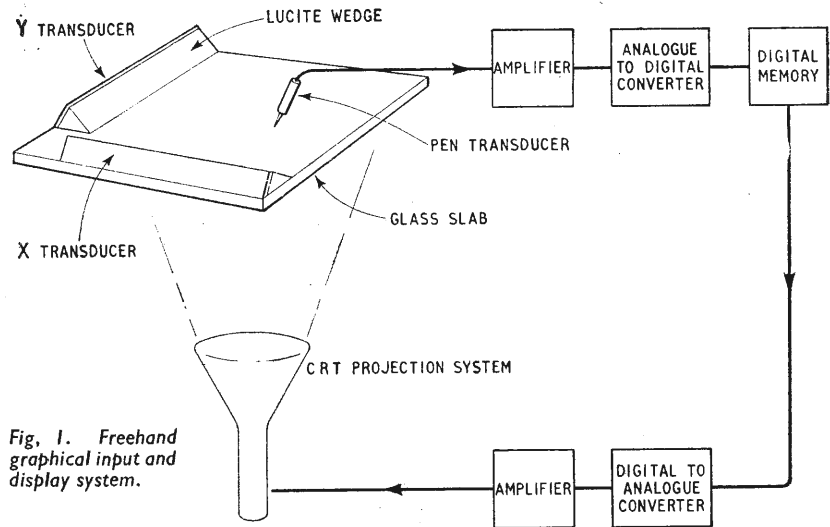

Fig. 1. Freehand graphical input and display system.

at the pen gives the co-ordinates of the pen and this information is converted into digital form and stored in a computer memory. When the information is required it is converted into analogue form and fed to a c.r.t. projection system and can conveniently be displayed on the glass slab.

Attenuation in the glass is minimized by using Rayleigh or surface waves as the mode of propagation and these are generated from longitudinal waves by mounting the barium titanate transducers at the critical angle (determined by Snells law) on a Lucite wedge.

A microswitch actuated by pressure

exerted on the pen causes a timing generator to start a counter and a binary trigger which operates alternately two AND gates is used to drive the x- and y- transducers (Fig. 2). On arrival of a vibration pulse at the lithium sulphate pen transducer the counter is stopped, reset and the count gated out to a digital memory. The next timing pulse then causes the other co-ordinate to be obtained.

Reflections from the discontinuity at the edge of the glass opposite to the transducers are required to be suppressed, and masking tape around the edges has been found to be satisfactory.

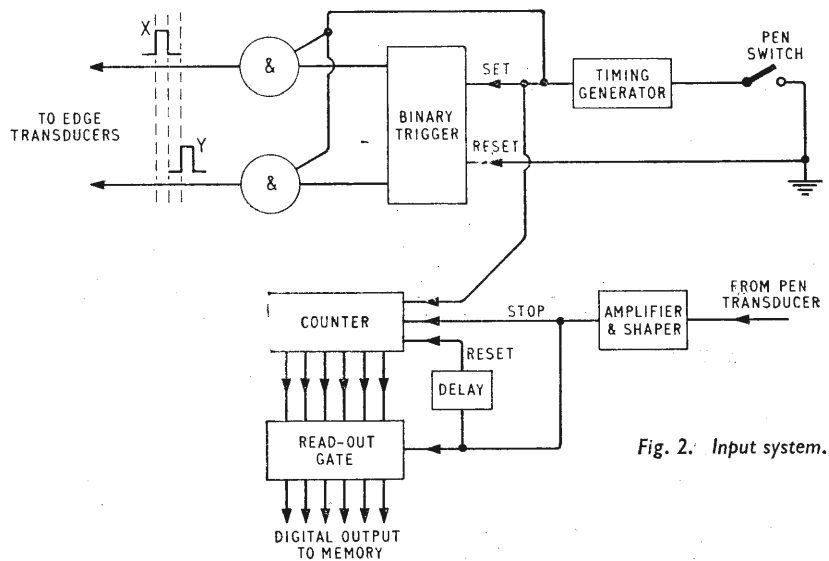
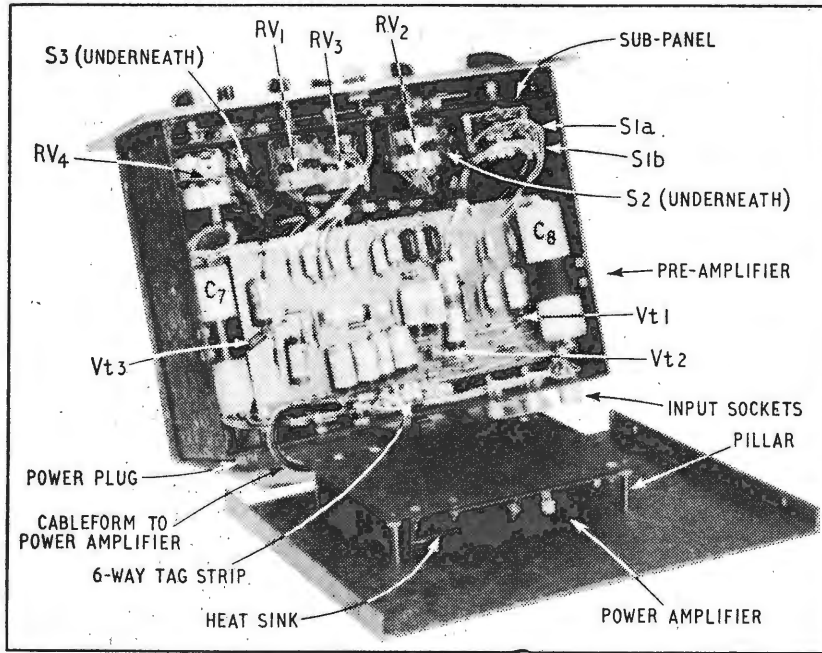

Fig. 2. Input system.

# TRANSISTOR



General view of interior with one "lid", carrying one of the power amplifiers, open

**T**HE new amplifier was built as an integrated stereo system containing two power amplifiers, pre-amplifiers, loudspeaker coupling capacitors and all controls, but omitting the mains power supply unit, since the amplifier was to be operated occasionally from batteries in open air public address functions for example.

**Metalwork:**—This was made entirely from 18 s.w.g. aluminium alloy as shown in the drilling and assembling diagrams. Construction was quite straightforward, and the liberal use of hank bushes simplified the assembly. The controls were mounted on a sub-panel behind the front panel to hide the unsightly bushes.

The metalwork was finished in black crackle enamel and stoved for 15 minutes in the kitchen oven at the lowest "Regulo" mark; too much heat will spoil the finish. After stoving, the panels should be left at room temperature for several days to allow the paint to harden. In order to achieve efficient earthing, the paint should be removed at all connecting surfaces before assembling the unit, and also at the co-axial input sockets. The only earth connection to chassis is signal earth at the input.

Heat sinks for the power amplifiers were integral with the chassis, being mounted on pillars below the top and bottom cover plates. It is important to maintain an earthed plate between the output transistors and the pre-amplifier (to avoid capacitive feedback) and also between the two channels to minimize crosstalk.

The holes in the heat sinks (Item 9) should be thoroughly de-burred before mounting, and a mica washer, smeared either side with silicone grease (ideally) or Vaseline, placed between the power transistor and the heat sink. The small plastic bushes should be inserted into the fixing holes from the heat sink side, so as to extend through into the power transistors, and the 6B.A.  $\times \frac{3}{8}$  inch screws should be tested after assembly to make sure they are insulated from the heat sink. A solder tag is used to make connection to the collector

## SPECIFICATION FOR COMPLETE STEREOPHONIC SYSTEM

<i>Output power</i>	.. ..	10 watts per channel
<i>Frequency response</i> ..	.. ..	35c/s to 20kc/s within 3dB
<i>Total harmonic distortion</i> ..	.. ..	0.3% at 1kc/s and 10 watts
<i>Signal-to-noise ratio (at ..</i>	.. ..	70dB (with controls level)
<i>10W output and with ..</i>	.. ..	50dB (with max. treble boost)
<i>earthed input)</i>		
<i>Channel separation</i> ..	.. ..	Radio — 60dB at 10kc/s
		Mic. — 50dB at 10kc/s
		Both figures improve by 15dB at 1kc/s
<i>Power requirements</i>	.. ..	40 volts at 800mA d.c. (max.) or 150mA (average) for 10 watts in two 15Ω speakers
<i>Controls</i> .. ..	.. ..	Input Selector (Microgroove, Standard, Radio, Microphone, Tape Replay), Treble, Bass, Filter, Volume, Balance, Function (Stereo, Reverse Stereo, Mono)
<i>Size</i> .. ..	.. ..	9½in × 3½in × 7½in deep. Front panel 10½in × 4½in
<i>Weight</i> .. ..	.. ..	5 lb 8 oz
<i>Max. ambient temperature</i> ..	.. ..	40° C

## PERFORMANCE OF POWER AMPLIFIER

<i>Power output</i>	.. ..	10 watts at 400 c/s
<i>Total harmonic distortion</i> ..	.. ..	0.2% at 1kc/s and 10 watts
<i>Output impedance</i>	.. ..	Less than 0.25Ω
<i>Input impedance</i> .. ..	.. ..	33kΩ
<i>Input voltage for 10 watts output</i> .. ..	.. ..	100mV
<i>Voltage gain constancy</i> ..	.. ..	Within ±1dB from 30c/s to 20kc/s

# HIGH-QUALITY AUDIO AMPLIFIER

Concluded from page 9 of the previous issue

By J. DINSDALE<sup>\*</sup> M.A.

(transistor case). See Fig. 17. The mica washers and plastic bushes are normally supplied with the power transistors.

**Wiring:**—The amplifiers were constructed on printed circuit boards, using both left and right hand printing to preserve symmetry and simplify connections to the controls and power supplies. All connections taken off the board (i.e., inputs, outputs, controls, and power supplies) were made to terminal pins (Harwin type). This greatly simplifies final assembly, and also enables boards to be removed at a later stage without difficulty. (It may also be

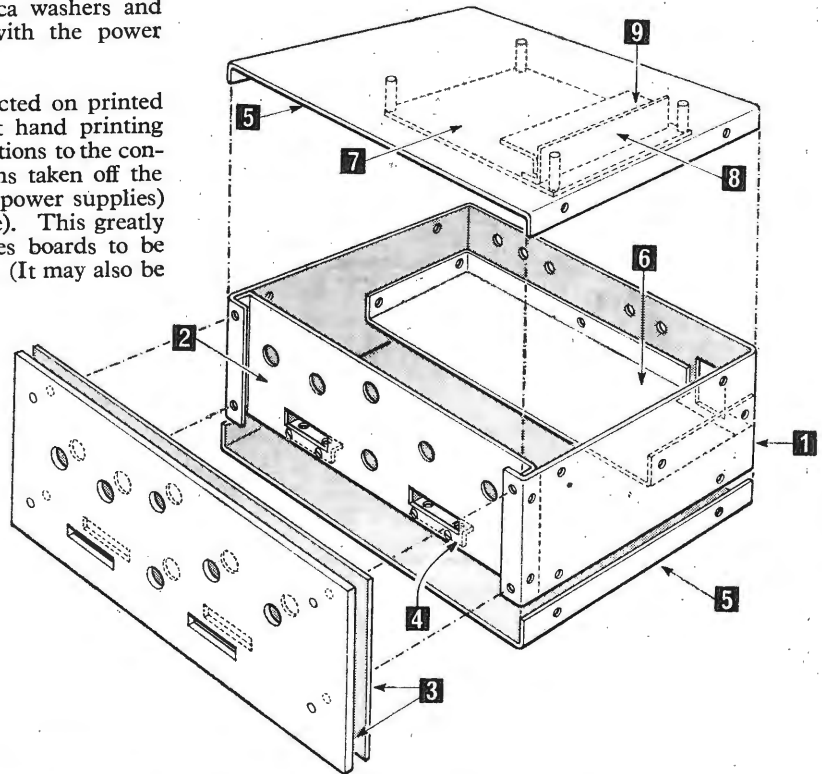

Fig. 16. Perspective drawing showing assembly of metalwork. The pre-amplifier circuit boards are mounted on either side of item (6).

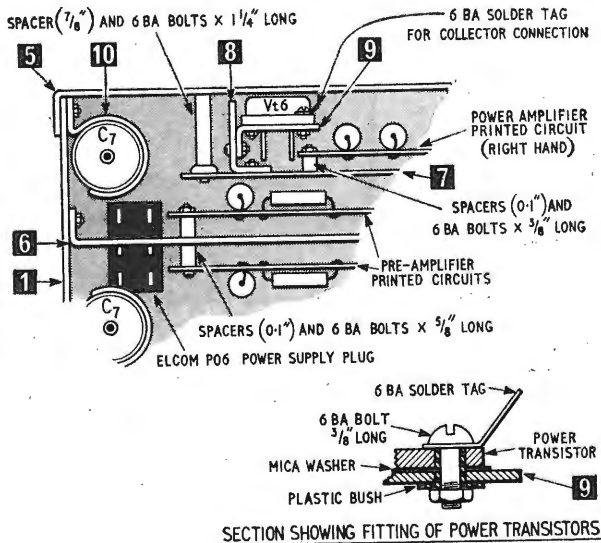

Fig. 17. Details of assembly and mounting of power transistors.

found worth while fitting terminal pins for all transistor leads; in this way, transistors may be replaced in the event of accident without access to the back of the board.) The printed circuit boards are bolted to the mounting plates using 6B.A. bolts, with additional spacers under each board to provide clearance for the soldered joints.

In order to ensure correct connectors to log/antilog potentiometer (RV<sub>3</sub>), the control should be turned to mid-setting (50% rotation) and the resistance from wiper to each end of the track measured for each gang. The two terminals with the *highest* resistance to wiper in this position (about 8-9k<sup>Ω</sup>) should be connected to the earth point on each pre-amplifier (marked RV<sub>3</sub> min in the printed circuit wiring diagram Fig. 20(b)) and the lower resistance terminals to RV<sub>3</sub> max.

While there are many alternative layouts it is important to separate signal and power earths throughout, as shown in Fig. 24. This is especially important on the control potentiometers, where a single "earth wire" is not satisfactory.

The photograph shows the main unit with one top

\*Elliott Brothers (London) Ltd.

cover and power amplifier removed. Interconnections between controls and boards are given in Figs. 22 and 23.

**Assembly:**—A six-way terminal block was fitted in each channel as shown to facilitate inter-board wiring.

The OAS diodes in the power amplifiers should be fitted into small metal clips and bolted to the heat sinks between the power transistors.

The two lever switches were mounted by removing the two bolts holding the wafer, and then re-assembling

Fig. 18. Drilling and bending details of metalwork items (1) to (4).

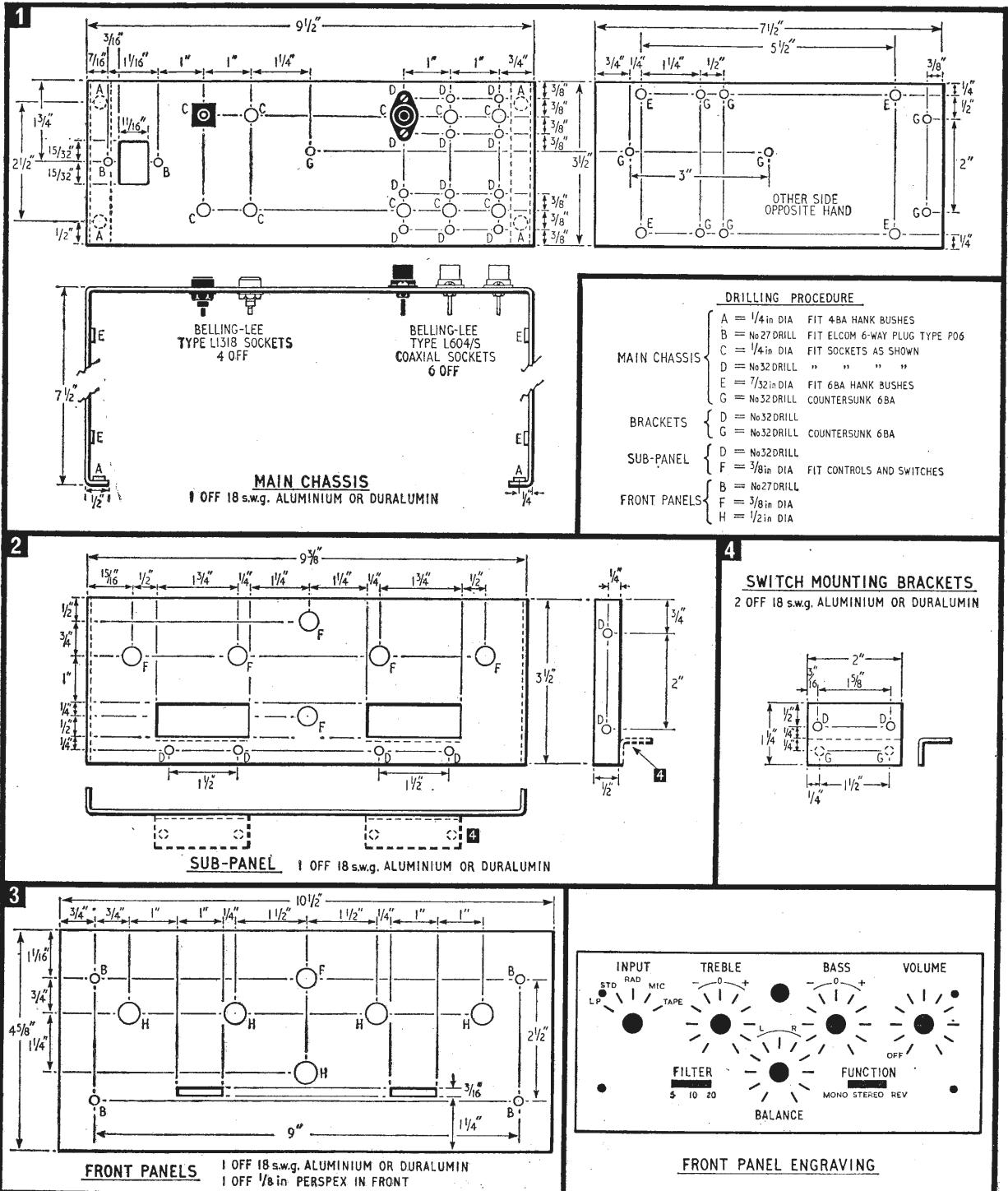



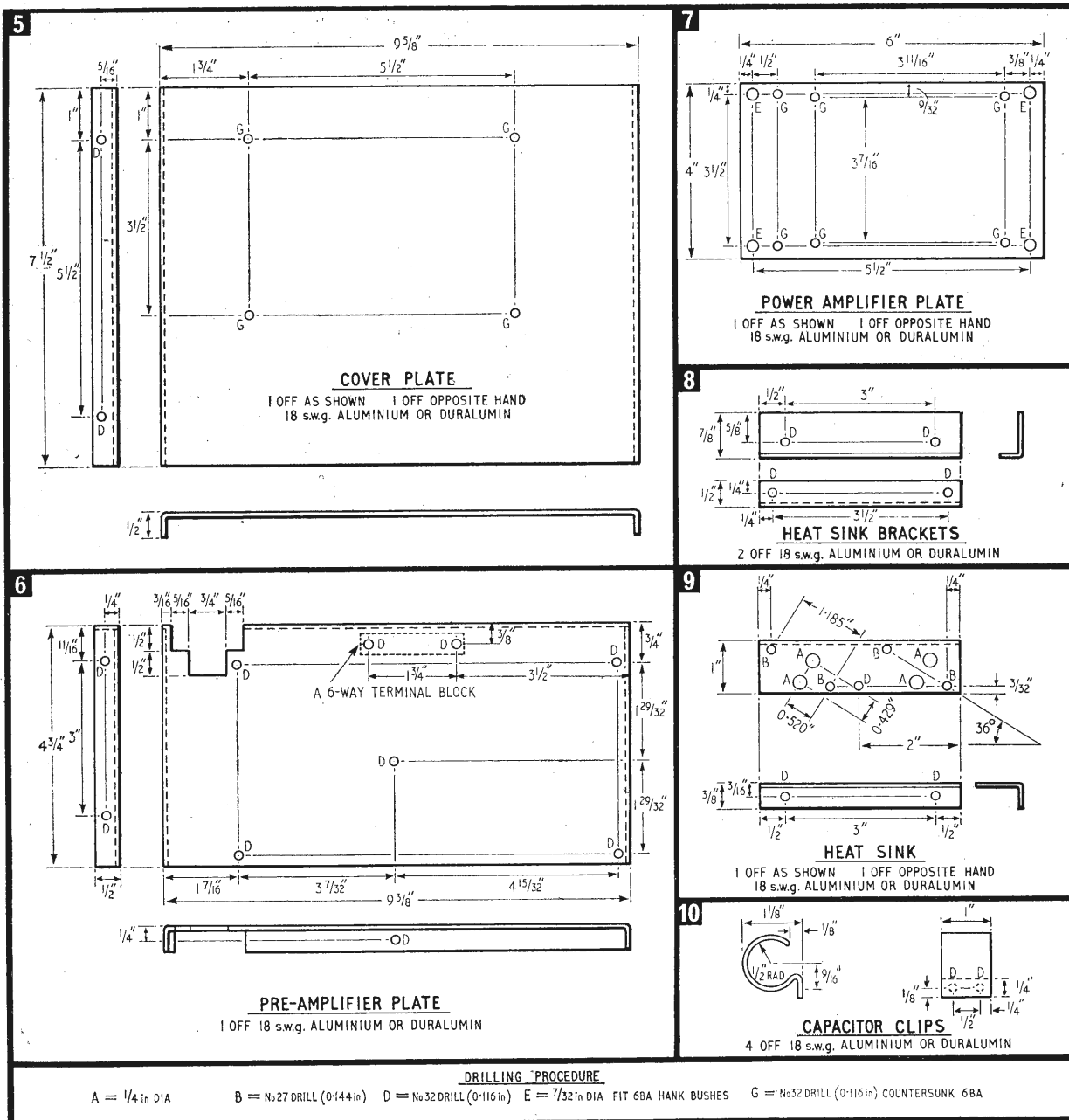

Fig. 19. Drilling and bending details of metalwork items (5) to (10).

the switch bolted to the special bracket on the sub-panel.

The wiring may be accomplished in a series of looms: one complex double loom for the front panel controls, and two looms for the power amplifiers; these latter are about six inches long to allow the covers to be removed. Looms are not essential, but wiring should be kept short. Twisted pairs should be used for the mains lead to the switch and for the pilot lamp.

The front panel was made as two units: one in  $\frac{1}{8}$  in Perspex and one in aluminium. The latter was painted a glossy grey, and the two were then assembled with a

sheet of tracing paper in between, on which the lettering had been printed.

The problem of ensuring correct earthing and the elimination of earth loops must always be borne in mind during construction; failure to do this can result in high distortion levels.

**Power Supply Switching:**—When the unit is to be run from the mains, it is convenient to switch the power supply unit with a switch ganged to RV<sub>1</sub>. Although this practice is generally frowned upon for use in high-quality equipment (on the grounds that the volume control will

Fig. 20. (a) Printed circuit pattern for one pre-amplifier (left and right hand sides to be transposed for the other amplifier). Large fixing holes  $\frac{1}{8}$ in dia. All pads may be drilled No. 64 (0.036in), except for transistor connections and holes for all external connections which may be No. 51 (0.070in) for Harwin terminal lugs, Type H2101B, used in prototype.

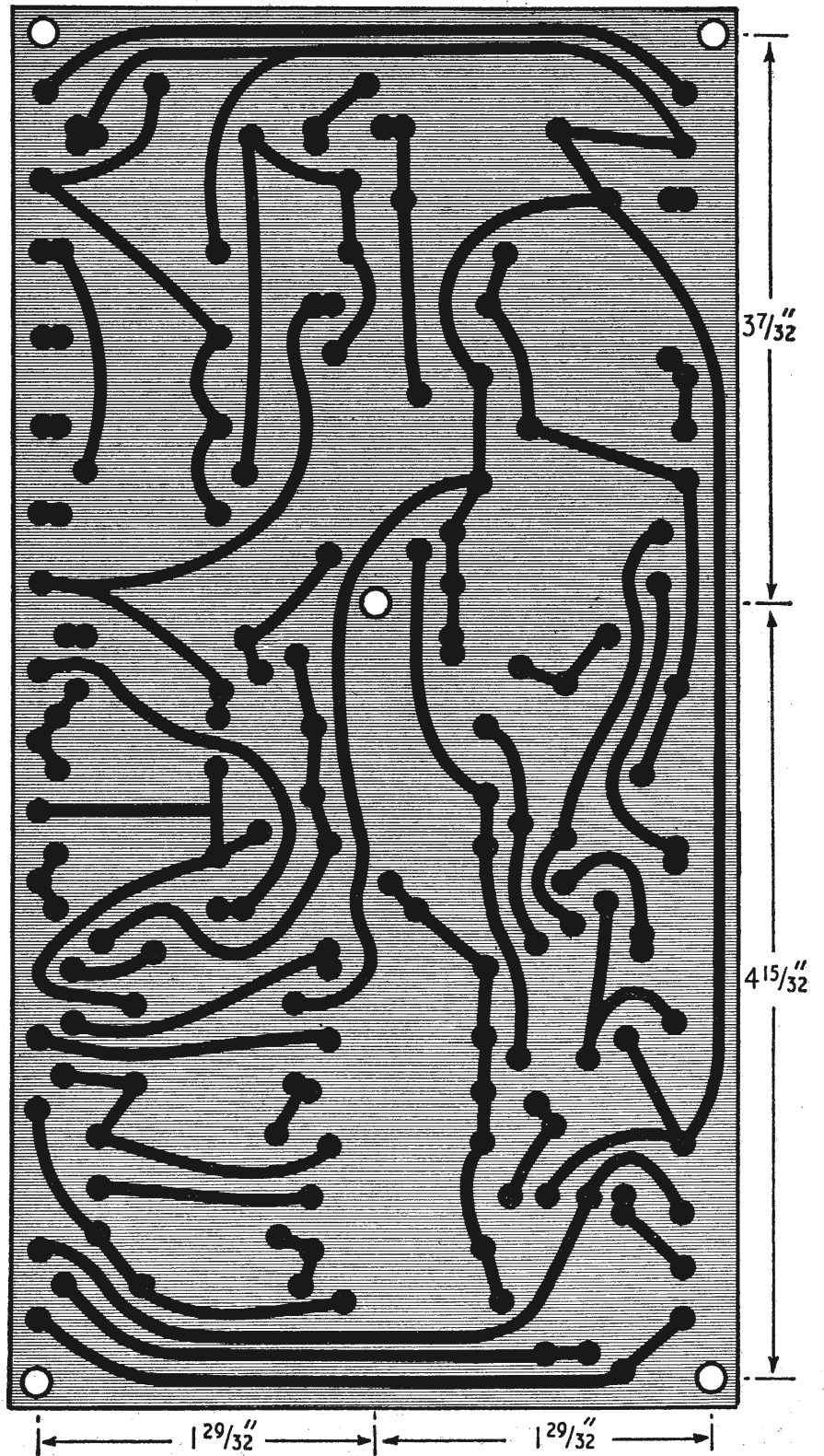

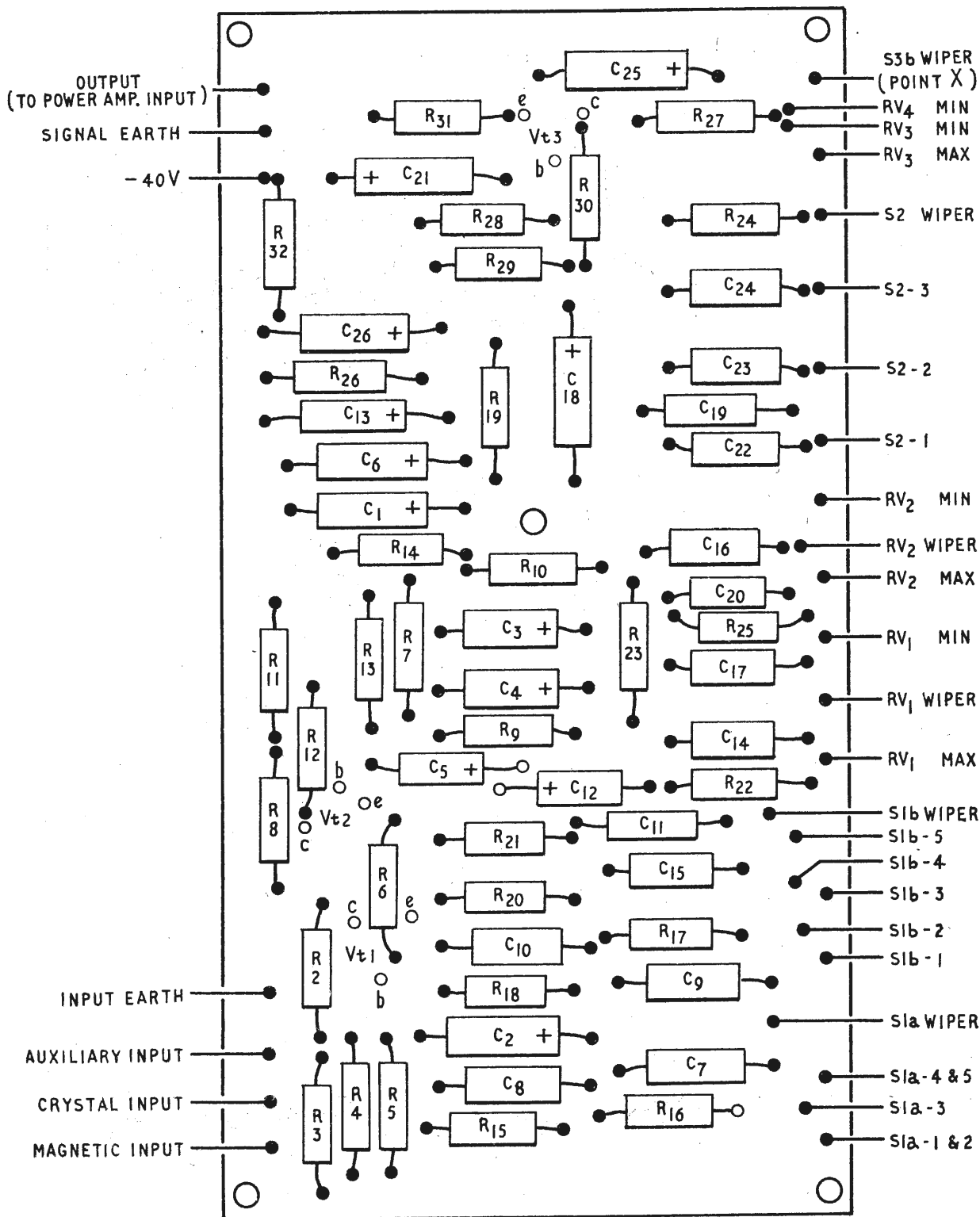

Fig. 20(b). Components on the pre-amplifier board as viewed on the underside of Fig. 20(a). R<sub>1</sub> is mounted on the rear of the Magnetic Input socket.

soon become noisy), it is desirable here to ensure that the volume control is on the minimum setting at the instant of switching on. This reduces switching surges and will protect the speakers if (for example) an input device has been connected incorrectly.

The connections to the 6-way power plug are

- 1 & 2—Mains switch
- 3 & 5—40V A & B
- 4 —Power earth
- 6 —Pilot lamp

The pilot lamp supply is rectified since the earth return is made via the power earth line. If a single 40V supply is used the lamp supply may be a.c.

If battery supplies are to be used (and the unit is ideally suited to these, since the quiescent current is under 40mA) then pins 3 & 5 may be connected together, and switched by the other pole of the double pole switch on RV<sub>4</sub>. The use of a single 40-volt supply (from either battery or mains unit) will produce a slight increase in crosstalk—negligible to many ears—and if this is acceptable, the switching of both mains and 40-volt lines by RV<sub>4</sub> can be a normal feature. However, if the 40-volt line is switched, the 2000 $\mu$ F reservoir capacitor in the power supply unit should be shunted by a 10 kilohm resistor to discharge the power supply when it is switched off.

**Testing:** As with all transistor apparatus, a little care when first switching on the newly built equipment will often save an expensive catastrophe.

The four units (2 power amps and 2 pre-amps) should be tested individually, applying the voltage in steps, preferably from a dry battery, and monitoring the current so that the presence of any fault condition is discovered before damage is done. Inputs should be connected to ground for this test, and transistor voltages compared with the typical values quoted. It should be noted that since the power amplifier has overall d.c. feedback a fault will affect the whole amplifier.

When all units are operating individually they may be assembled into the case, and the final wiring completed.

Note that with the heat-sinks shown, continuous testing at full

Fig. 21. Printed circuit pattern and component positions of one power amplifier. Drilling details as for Fig. 20(a). The two power transistors are mounted separately (see Fig. 17).

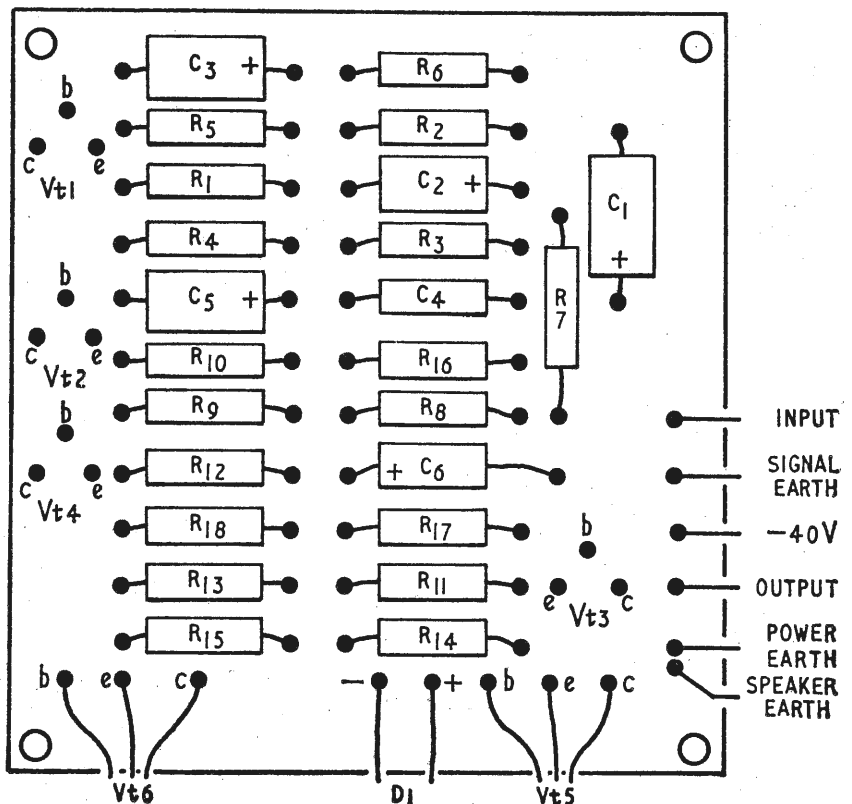
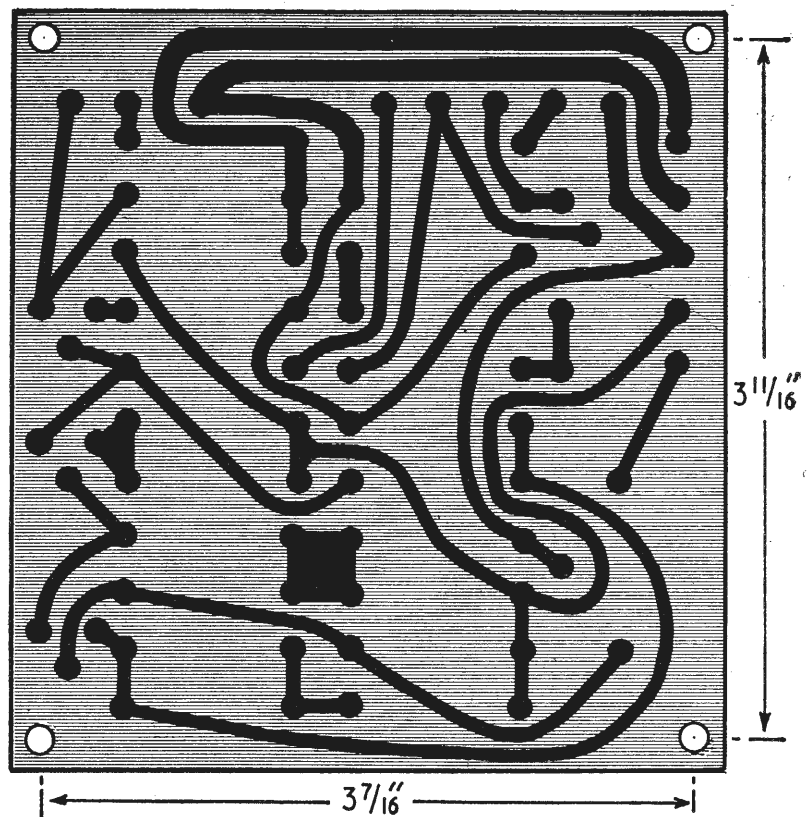

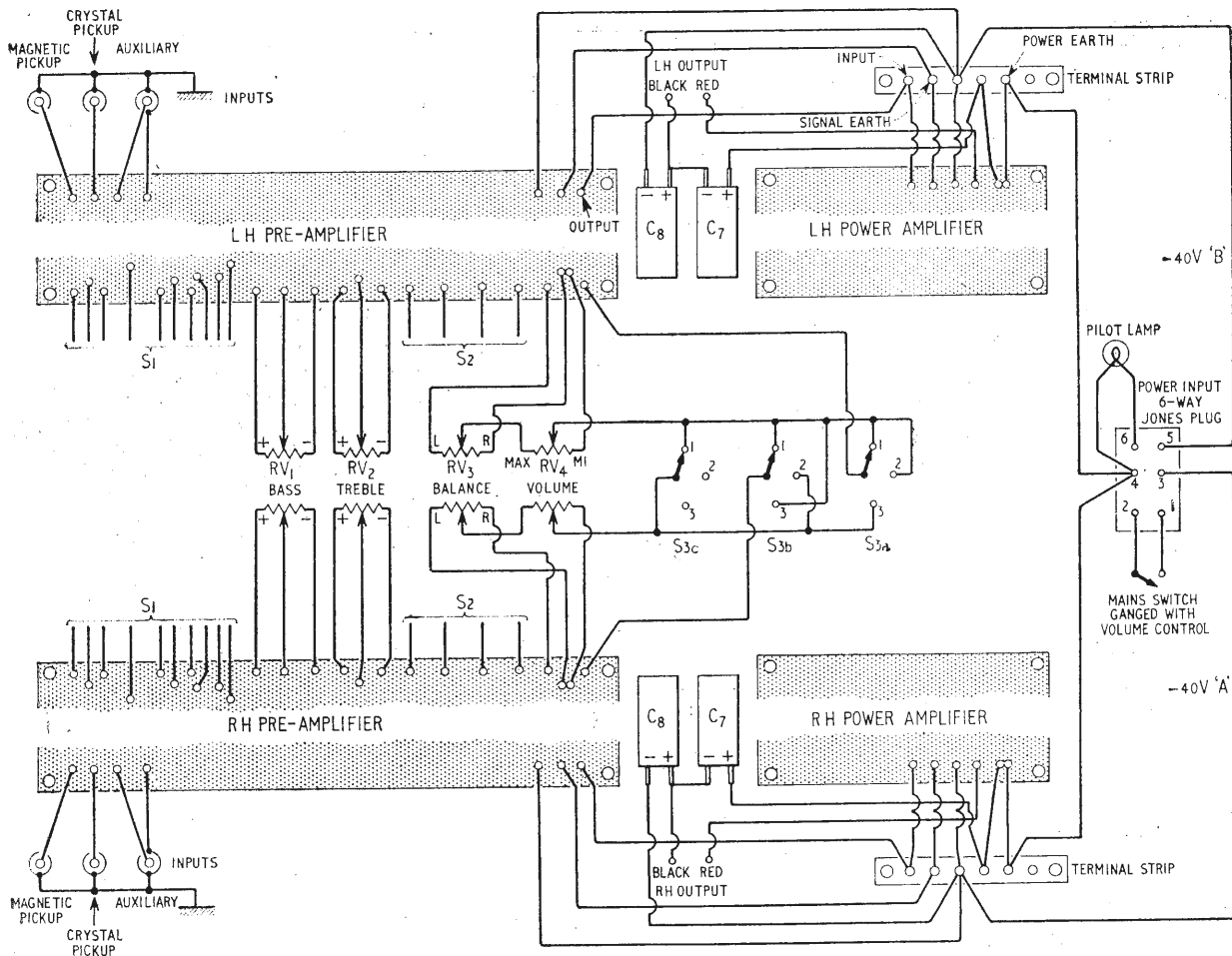

Fig. 22. Interconnections of circuit boards, controls and peripheral components. See text for method of connecting the balance control (RV<sub>3</sub>) potentiometers.

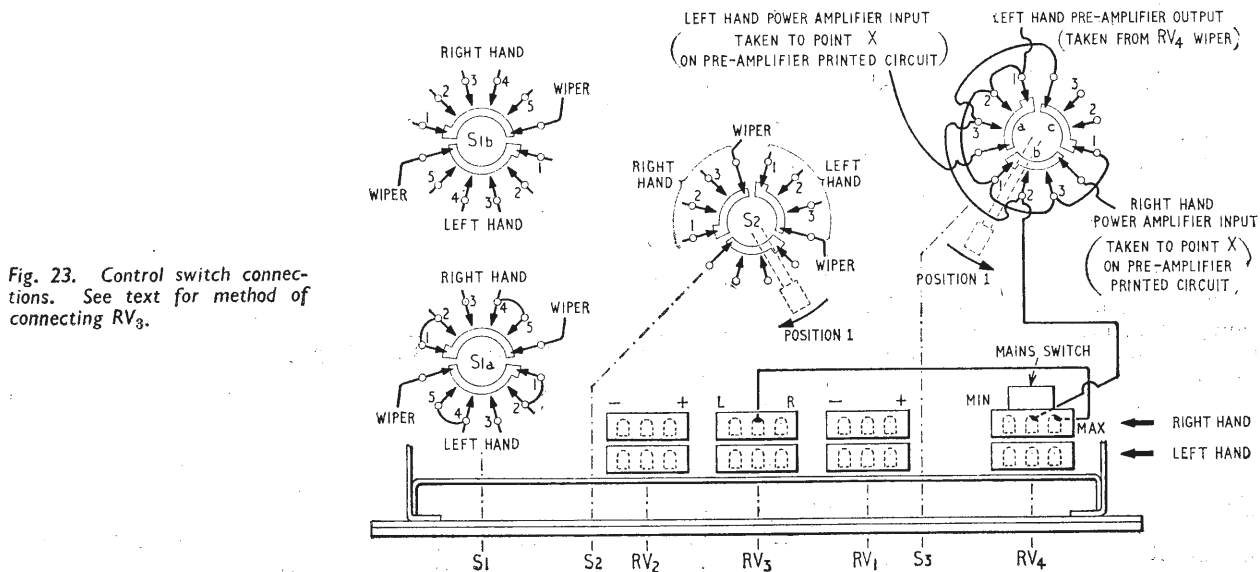

Fig. 23. Control switch connections. See text for method of connecting RV<sub>3</sub>.

**INPUT DATA FOR PRE-AMPLIFIER**

Switch Position	Function	Sensitivity at 1 kc/s	Input Impedance
1	Microgroove	Magnetic Crystal* 4mV 400mV	100kΩ 68kΩ
2	Standard	Magnetic Crystal* 8mV 800mV	100kΩ 68kΩ
3	Radio	80mV	92kΩ
4	Microphone	5mV	92kΩ
5	Tape replay	3mV	92kΩ

\*With 1kΩ resistor across Magnetic Input A.

**PRE-AMPLIFIER TRANSISTOR VOLTAGES**

Transistor	c	b	e
Vt1	-1.9	-1.3	-1.15
Vt2	-3.9	-1.9	-1.75
Vt3	-2.6	-1.4	-1.25

40 volt supply, dropping to 13 volts after R<sub>32</sub> (Measured on appropriate Range of Model 8 AVO meter)

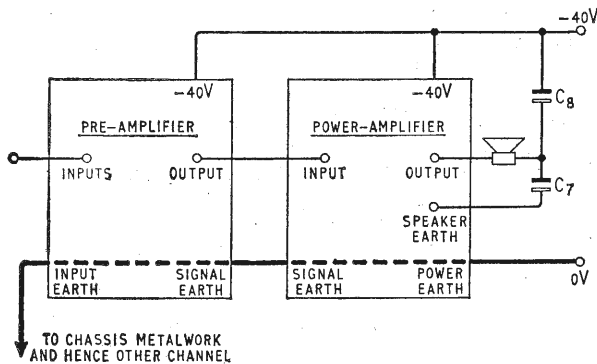

Fig. 24. Correct earthing of printed circuits.

power should not be undertaken except in 2-second bursts with 5-second "rest periods" in between. This gives, incidentally, enough time to make a reading, followed by sufficient to write down the reading and set the frequency to the next value before reconnecting the input.

**Noise:**—The performance of the amplifier with regard to noise and, when used with a mains unit, hum, is extremely good, being better than 70 dB down on full output.

A word of warning however: the noise depends almost entirely on Vt1 and Vt2 in the pre-amplifier and Vt 1 in the power amplifier, and although the operating conditions are chosen to minimize noise, the occasional specimen may be found unsatisfactory in this respect, when it should be changed. In fact transistors are extremely variable in this parameter—the author has found variations of 50dB in noise factor between transistors of the same type from the same packet. Transistors with a doubtful past history of use (or abuse) are particularly to be avoided on this account.

Table III gives typical voltages on the transistors as an aid to setting up and fault finding in the main amplifier.

Several new transistors have appeared which are suitable for the design, and a list of transistor equivalents has been included in Table IV.

**TABLE III**

Transistor	c	b	e
Vt1	-2.2	-1.5	-1.3
Vt2	-18.7	-2.2	-1.95
Vt3	-40	-19.1	-19
Vt4	-0.15	-18.7	-18.8
Vt5	-40	-19	-18.8
Vt6	-18.9	-0.15	-0.01

40 volt supply, quiescent current=25 mA (total). (Output stage current=14 mA). Output 18.9 volts.

**TABLE IV**

Transistor Number	Type	Gain (Typical)	Voltage Working	Typical Types
1	p-n-p Small signal high frequency	High (100)	6	OC44 XA102*
2	p-n-p	Medium (50)	40	OC77 ACY17 XB121* NKT227
3	p-n-p	Medium (30 at 100mA)	40	OC77 ACY17 XB121* NKT227
4	n-p-n	Medium (30 at 100mA)	40	2N388A 2N385A SYL1750
5 & 6	p-n-p Power	Medium (30 at 3A)	40	OC29 OC35 OC36 2N457 2N257 NKT401 GET572*

\*Obsolete type which may still be available.

**Errata:**—In Table 1, p. 3 of the January issue the value of R8 should be 22 kΩ, and in Fig. 6 the network referred to is, of course, that of Fig. 4.

In Fig. 2, R<sub>28</sub> and R<sub>29</sub> should be connected to the left-hand end of R<sub>26</sub>.

It is regretted that an incorrect block was inserted in the position (Fig. 12, p. 7) which should have been occupied by the circuit of the original power amplifier. The correct circuit is given below.

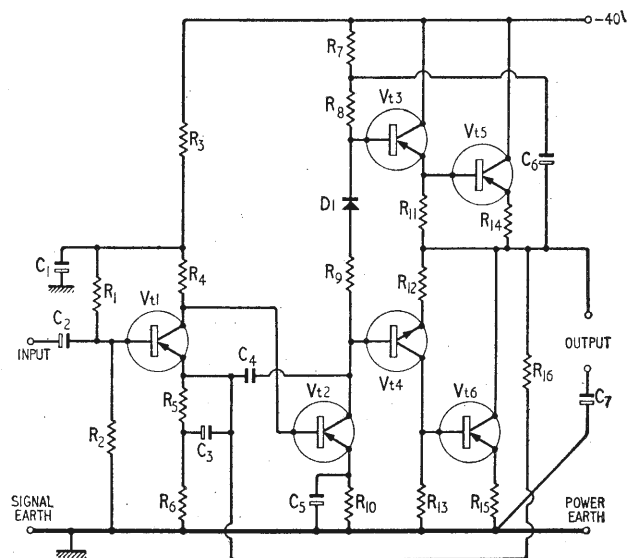

Fig. 12. Circuit of original power amplifier.

# MANUFACTURERS' PRODUCTS

## NEW ELECTRONIC EQUIPMENT AND ACCESSORIES

### Transistor Service Pack

A LEAFLET with data and general notes to assist service engineers with the problem of semiconductor replacement in long- and medium-wave band receivers is included in a kit of replacement semiconductors Mullard's have introduced under the title "10+1 A.M. Transistor Pack." The leaflet is not an equivalents list, but a list of similar types and has been prepared from other manufacturers' published data.

The semiconductor section of the kit comprises an OC45 (a.f. amplifier stages), OC71 (low-consumption audio output stages), 2×OC44 (oscillator-mixer stages), 2×OC81 (audio output stages), 2×OC81D (audio driver stages), 2×AF117 (r.f., i.f. and oscillator-mixer stages) and an OA90 (detector). The price of the pack is £4 5s.

2WW 301 for further details

### Function Generator Incorporating Ramp Generator

APART from providing simultaneous outputs of square, sine, sawtooth and triangular waveforms of up to 25 volts p.-p. over a frequency range 0.001 c/s to 10 kc/s, the Model 255 function generator from Exact Electronics Incorporated incorporates a separate ramp generator which is capable of delaying, triggering or gating the main generator. This enables a wide variety of different waveforms composed of basic sine, square, triangle and sawtooth to be produced and should fulfil many low frequency requirements in such fields as vibration, medical electronics and computer programming. The instrument is priced at £353 (excluding duty and other Government charges) and is available in this country through Livingston Laboratories Ltd., of 31 Camden Road, London, N.W.1.

2WW 302 for further details

### Non-polar Tantalum Electrolytics

A RANGE of non-polar tantalum electrolytic capacitors, designated ANP, is being produced by the dielectric and magnetic division of Plessey-UK Ltd., of Towcester, Northants. Although similar in appearance to the A and AHS "Castanet" types, the ANP units are considerably smaller and housed in two

cans sizes ( $\frac{1}{8}$ in and  $\frac{5}{16}$ in deep). The ANP series covers the capacitance range 15  $\mu$ F to 470  $\mu$ F and voltage range 3 V to 75 V at 125° C. The leakage current at rated voltage is quoted to be not greater than 2  $\mu$ A after three minutes at 25° C. Sintered high-purity tantalum powder is used for the twin electrodes to give maximum surface area per unit volume. This, the maker's claim, results in better power factors, lower noise levels and improved reliability.

2WW 303 for further details

### Miniature Mains Transformers

A NEW range of miniature mains transformers, that occupy less than a cubic inch of space, is announced by the Belclere Company Ltd. of 385-387 Cowley Road, Oxford. The actual dimensions are  $1\frac{1}{2} \times 1 \times \frac{3}{4}$ in, and they weigh approximately 1½oz.

These units are designed to operate from either 110 or 240-volt 50 c/s sup-

plies, and provide 40 mA at 12 volts. Several types are available including ones for printed circuit board and chassis applications and also one completely enclosed in a Mumetal screening can  $1\frac{1}{4}$ in high  $\times 1\frac{1}{4}$ in diameter, with a  $\frac{3}{8}$ in hollow fixing bush at one end.

2WW 304 for further details

### Continuous Loop Recorder/ Reproducer

DESIGNED for industrial applications is the Type GL-2810 continuous loop recorder and play-back machine from the Consolidated Electro-dynamics Division of Bell and Howell Ltd., of 14 Commercial Road, Woking, Surrey. The tape transport accommodates half-inch and one-inch tapes and can drive them at any one of six speeds from  $1\frac{1}{8}$ in to 60in/sec.

Applications for this instrument include analysis of vibration and acoustic data recorded from structural

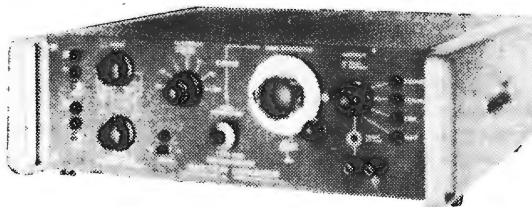

Model 255 function generator incorporating a separate ramp generator, for low frequency applications, from Exact Electronics Inc. of Oregon, U.S.A.

Mullard transistor service pack. It contains ten transistors and a diode.

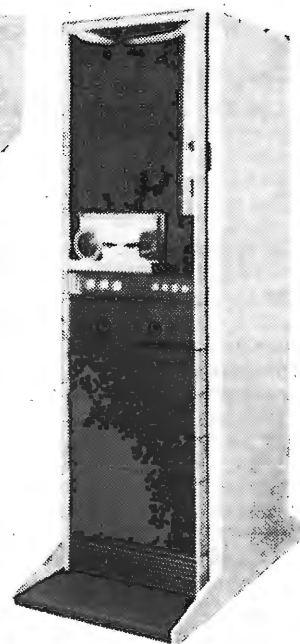

Continuous loop recorder/reproducer introduced by the Consolidated Electro-dynamics Division of Bell and Howell Ltd.

tests, pressure transient recordings, and parameters whose recorded waveforms are complex. The instrument can also be used for environmental testing and life testing of products requiring complex analogue repetitive input signals.

2WW 305 for further details

### High-power Ultrasonic Magnetostrictive Transducers

THE 500 Series of ultrasonic magnetostrictive transducers which operate from either 20 or 30 kc/s power supplies and are suitable for converting up to 500 watts of energy into ultrasonic vibrations is announced by Omega Laboratories Ltd., of 57 Union Street, London, S.E.1. At present four different models are available, two that have 150-watt ratings and two that have 500-watt ratings. One from each power range is suitable for 20 kc/s operation and the other is designed for use at 30 kc/s.

The lower power models operate with direct air cooling while the higher power transducers utilize forced-air cooling. The construction of these units is such that static pressures can be applied during welding operations (for which these units are primarily intended) both axially and at an angle, and probe tips for longitudinal vibrations or shear wave application can be supplied if required.

Suitable power supplies, rated up to 500 watts, are also available for these units.

2WW 306 for further details

### Digital Memory Oscilloscope

A MAGNETIC-CORE memory and a feedback error-sensing circuit form the heart of the Model NS-513 digital memory oscilloscope that has been developed by Northern Scientific Incorporated, of Wisconsin, U.S.A., to extract recurring signals buried in noise and present them either in digital form or on an internal c.r. tube.

Simply, the method employed by this instrument involves averaging the level of signals present at a large number of co-ordinate points (512 in fact). The signals of interest provide a high proportion of the average level at the co-ordinate points because the level of the random noise (being positive and negative) tends to cancel itself out and thus add very little to the average figure. The signal-to-noise ratio of the averaged signal is proportional to the square root of the number of signals averaged and to obtain a tenfold improvement another hundred co-ordinate points have to be analysed.

The sampling rate of the instrument is 25,000 per second and the overall accuracy is quoted to be within 0.1%.

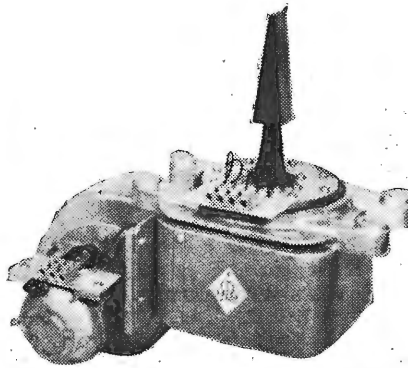

Magnetostrictive 500 watt transducer from Omega Laboratories Ltd.

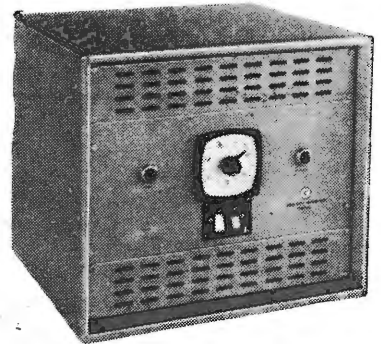

Standard 10 kW proportional temperature control unit from Kent Precision Electronics Ltd.

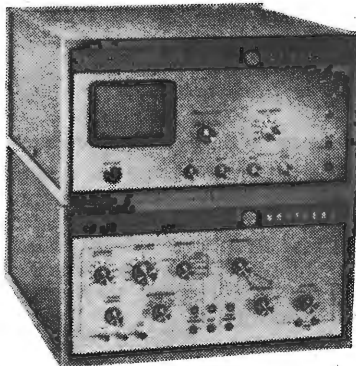

Northern Scientific NS-513 digital memory oscilloscope.

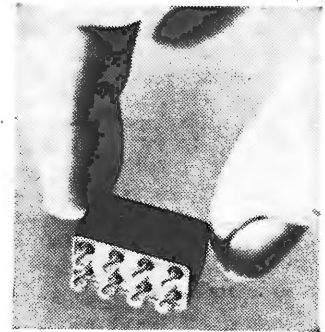

Sub-miniature relay with 2-A contact ratings, at 30 V, developed by Hi-G Incorporated.

Signals from 0.1 to 100 volts can be accommodated and an input impedance of  $1M\Omega$  is achieved at all attenuator settings. Sweep speeds range from 0.02 to 200 seconds per sweep.

The NS-513 is available in the United Kingdom through High Volt Linear Ltd., of 1 Cardiff Road, Luton, Beds. Excluding duty and other Government charges, the instrument costs £3,630.

2WW 307 for further details

### Temperature Control Systems

SOLID-STATE temperature control instruments to provide control of electrical furnace temperatures up to  $2,000^{\circ}\text{C}$  with an accuracy of 0.5% are announced by Kent Precision Electronics Ltd., of Vale Road, Tonbridge, Kent.

Conventional temperature transducer elements that provide a signal proportional to temperature of the furnace are used and their output is compared with a reference signal. The resultant d.c. voltage is used to control a thyristor power output stage which regulates the power to the heating elements of the furnace. In the instruments for larger systems, where the heating current

exceeds 100A, low-power thyristor output circuits are used to drive either a saturable reactor—for proportional control—or electromagnetic contactors for straightforward on-off control of the heating elements.

2WW 308 for further details

### Subminiature Relay

A SMALLER version of the half-size crystal-can relay (with the trade mark Half-Pint) has been developed by Hi-G Incorporated, of Spring Street and Route 75, Windsor Locks, Connecticut, U.S.A. This new relay, designated Series K, is only 0.400 in in height and is designed to meet all the requirements of MIL-R-5757D/9. The switching time has been improved through a reduction in the mass of the two-pole, double-throw contact assembly and under standard conditions of nominal coil voltage at  $25^{\circ}\text{C}$ , typical make times of around 2.5 milliseconds and break times as low as 1 millisecond have been achieved. Contact ratings are quoted to be 2 A (resistive) at 30 volts d.c. and the ambient temperature range of the relay is  $-65^{\circ}\text{C}$  to  $+125^{\circ}\text{C}$ .

2WW 309 for further details



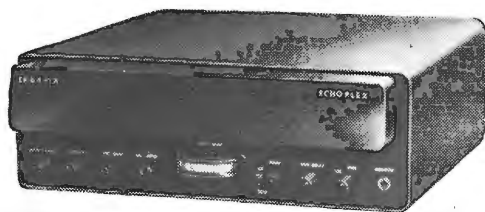

"Echoplex" scrambler for amateur and low cost commercial communication applications. (Kahn Research Laboratories.)

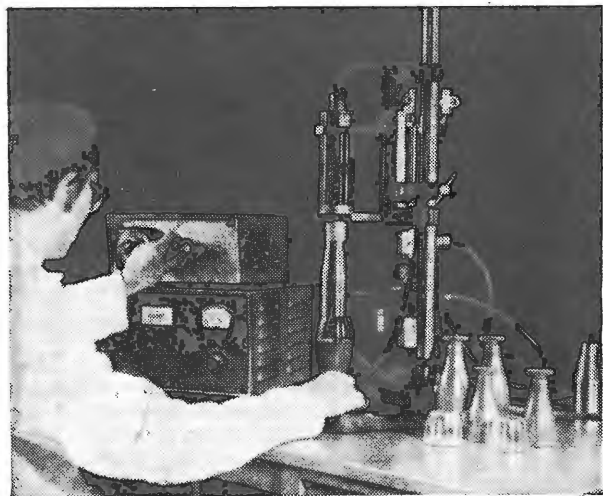

Dawe Type 1133 Sonicwelder, complete with automatic timer, being used to weld plastic containers.



Bio-medical laser system from the Raytheon Company, U.S.A.

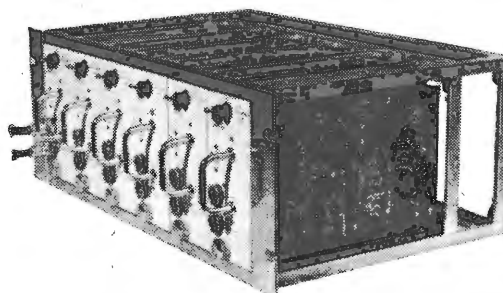

Six-channel amplifier for low signal level applications. (Fenlow Electronics Ltd.)

### Communications Scrambler

PRIMARILY intended for use by radio amateurs but also suitable for low cost commercial communication networks, is the new version of the "Echoplex" scrambler unit from Kahn Research Laboratories Incorporated, of 81 South Bergen Place, Freeport, Long Island, New York. It is an audio processing device which encodes the input by separating it into six frequency elements with six band-pass audio filters. Two of the filter outputs are fed directly to the transmitter, two others are passed through a one second delay circuit and the other two through a two second delay before being fed to the transmitter. In the receiving mode this procedure is simply reversed. The "Echoplex" is a passive device with variable gain, up to 7 dB, and has monitoring facilities.

2WW 310 for further details

### Bio-Medical Lasers

A LASER system (MS-2) comprising a pulsed ruby laser and a c.w. helium-neon laser is announced by the Raytheon Company. The lasers are primarily intended for bio-medical use but the system can also be used for

general laboratory applications. Included is a "Laser Applicator" which is used as a sighting device and also to measure the output energy.

The water-cooled ruby laser, a modification of the Raytheon LH8, can be pulsed at five-second intervals with an adjustable output of up to 50 joules. The input energy is monitored and the output level is claimed to be repeatable to within 2%. The output of the helium-neon laser is also adjustable up to a maximum of 20 mW at 6328 Å.

2WW 311 for further details

### Ultrasonic Plastic Welder

AN ultrasonic welding machine for welding rigid thermoplastic materials is announced by Dawe Instruments Ltd., of Western Avenue, Acton, London, W.3. Known as the Type 1133 Sonicwelder, it comprises a transistor 250 watt, 20 kc/s generator and a converter employing a ceramic lead zirconate transducer, whose output is concentrated and intensified by a transformer (or horn) which acts as a connector to one of the items to be welded. Heat is only generated at the junction of the two components and provides an

almost instantaneous weld. Quite sturdy materials can be joined using this process.

2WW 312 for further details

### Ninety-watt Transistors

IDENTIFIED as the CQT range, a new series of p-n-p germanium 90-watt power transistors, suitable for audio and switching applications, has been introduced by the Brush Clevite Co. Ltd., of Hythe, Southampton, Hants. The range comprises six units, which are all cased in Type TO-3 cans, and have maximum collector-to-emitter voltage ratings from 40 to 140 V. The frequency at which the gain is at unity is 200 kc/s.

As an example of the price of these transistors, the Type CQT 1075 (which has a  $V_{CE}$  of 140V, a maximum  $I_c$  of 25 A and a minimum d.c. current gain of 40 at 10 A, 2 V) costs 42s 6d for medium quantity supply.

2WW 313 for further details

### Multi-channel Amplifier

A NEW six-channel amplifier, with separate gains individually variable from 330 to 2,400, designed to amplify low

level signals from thermocouples, strain gauges and transducers is announced by Fenlow Electronics Ltd., of Springfield Lane, Weybridge, Surrey.

This unit, known as the Type R6, is suitable for rack-mounting in standard 19-in assemblies and having an input impedance of 100 M $\Omega$  does not load the source. Photo resistive choppers are used in the amplifiers and give them a drift characteristic of less than 0.2  $\mu$ V per degree C. The bandwidth of the amplifiers is 20 kc/s and an output current of 25 mA can be obtained, thus making them suitable for driving ultra-violet recorders.

2WW 314 for further details

### Two-watt Photocell

A NEW range of small, high wattage photo-conductive cells has been developed by the Clairex Corporation in the United States. The range provides a choice of photosensitive materials, including cadmium sulphide and selenide, and offers a variety of combinations of spectral response, sensitivity and response time to suit different applications. The continuous dissipation rating for these devices is two watts. Known as the CL5M Series, these units are available in the United Kingdom through Walmore Electronics Ltd., of 11-15 Betterton Street, Drury Lane, London, W.C.2.

2WW 315 for further details

### Low-frequency Spectrum Analysers

TWO spectrum analysers, one covering 1 c/s to 4 kc/s, and the other covering 20 c/s to 30 kc/s, have been developed by Intercontinental Instruments Incorporated and are now available in this country through the instruments division of Claude Lyons Ltd., of 76 Old Hall Street, Liverpool, 3 (southern offices Hoddesdon, Herts).

Both instruments employ transistors throughout and are somewhat similar. The one that covers the lower fre-

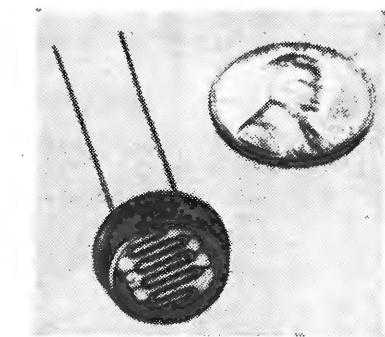

Two-watt photocell with a diameter of only 0.5in developed by the Clairex Corporation.

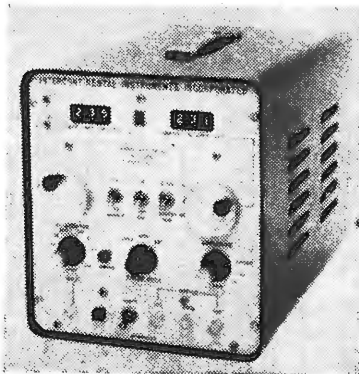

Model HSA-2 spectrum analyser from Intercontinental Instruments Incorporated

quency band, the HSA-1, features an in-line digital display, which is accurate to 1% in the wave analyser mode, and an internal sweep generator for automatic frequency scanning. A special feature of this instrument is the inclusion of a beat frequency oscillator whose output is equal to the analysis frequency and moves in synchronism with the sweep oscillator. This enables frequency to be measured to an accuracy of 0.5 c/s.

The other, the HSA-2, is a dual function instrument inasmuch as it can be

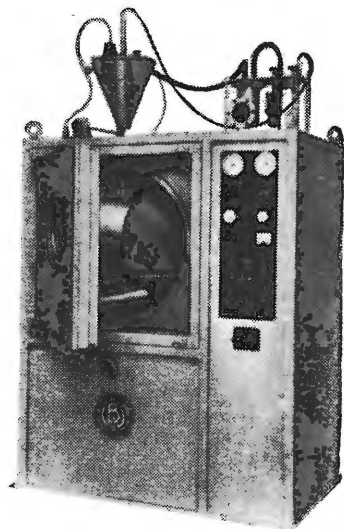

Self-contained vacuum encapsulation casting and potting plant, with mixing and dispensing unit for use with epoxy resins, from Barlow-Whitney Ltd.

used as a manually-tuned wave analyser and as an automatic-scanning spectrum analyser. Features of the HSA-2 include a beat frequency output, automatic frequency tracking and an output suitable for oscilloscope display.

2WW 316 for further details

### Vacuum Encapsulation Plant

AN entirely new range of standard vacuum equipment specially designed for the electrical and electronics industries for encapsulation, casting and potting processes using the latest epoxy resins is announced by Barlow-Whitney Ltd., of Coombe Road, Neasden, London, N.W.10.

All models are completely self-contained and only require connection to normal factory services. Table diameters from 12 to 24 in are included in the standard range, and for special applications a number of optional features can be added. These include a remotely operated dispensing valve for handling small components, and measuring flasks—with and without stirrers—to enable users to precisely dispense measured quantities of mixed resin.

2WW 317 for further details

### Regulated Power Supply Kit

CAPABLE of delivering up to 1.5 A at any specified voltage within the range 0.5 to 50 V d.c. is the easily-assembled Heathkit IP-20U. Transistors are used throughout this power supply which features an automatic current limiting device to protect the load, as well as its

(Continued on page 8)

### INFORMATION SERVICE FOR PROFESSIONAL READERS

To expedite requests for further information on products appearing in the editorial and advertisement pages of *Wireless World* each month, a sheet of reader service cards is included in this issue. The cards will be found between advertisement pages 16 and 19.

We invite readers to make use of these cards for all inquiries dealing with specific products. Many editorial items and all advertisements are coded with a number, prefixed by 2WW, and it is then necessary only to enter the number(s) on the card.

Readers will appreciate the advantage of being able to fold out the sheet of cards, enabling them to make entries while studying the editorial and advertisement pages.

Postage is free in the U.K., but cards must be stamped if posted overseas. This service will enable professional readers to obtain the additional information they require quickly and easily.

own circuitry, and an overload relay for the protection against severe overloading as in the case of a direct short.

The instrument draws 136 watts when fully loaded and will operate from any 100 to 125 or 200 to 250 V, 40 to 60 c/s supply. Specification features include a load regulation figure of 15 mV; line regulation of less than 0.005% change for a 5% deviation in supply; 25  $\mu$ sec transient response; output impedance less than 0.1  $\Omega$  from d.c. to 10 kc/s and less than 0.5  $\Omega$  above this frequency. The dimensions are 9½ × 6½ × 11 in; net weight is 16 lb. The kit is priced at £35 8s and will be available next month from Daystrom Ltd., of Gloucester.

2WW 318 for further details

### Edge Control Rotary Switch

A TEN-POSITION single-pole rotary switch with a printed circuit board stator is announced by N.S.F. Ltd., of 31-32 Alfred Place, London, W.C.1. This switch, which should be of particular interest to those in the instrumentation and control fields, is suitable for stack-



Heathkit Model IP-20U regulated power supply.

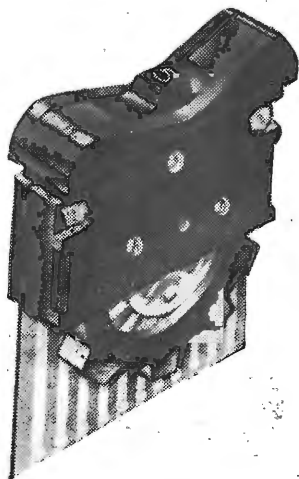

Edge control rotary switch with a printed circuit board stator (N.S.F. Ltd.).

ing (up to 12) and has an adjustable stop that can limit rotation to any position between 2 and 10. The contacts can be arranged so that they make before they break or vice versa. Terminal connections can be made directly to eyelets on the printed circuit board, which incidentally can be varied to meet user requirements.

2WW 319 for further details

### Portable V.H.F./U.H.F. Receiver

DESIGNED for single-channel operation in the 430 to 470 Mc/s band and the 70 to 90 Mc/s band is the new Type TR40/20 transistor receiver from the VHF/UHF Communications Company, of 16 Abbey Street, Crewkerne, Somerset. It is a portable unit designed for use in systems with 25 kc/s channel spacing and operates in the triple superhet mode at u.h.f. and the double superhet mode at v.h.f. Low battery consumption is a feature of this receiver and the internal eight-volt mercury battery is claimed to give approximately 70 hours use. An internal loudspeaker is

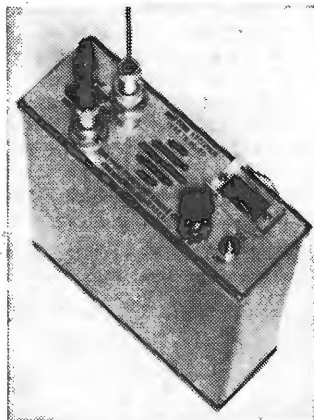

Portable v.h.f./u.h.f. receiver Type TR40/20 being manufactured by the VHF/UHF Communications Company.

Model 2601A transient detector suitable for measuring voltage peaks from 100 mV to 5,000 V. (Huggins Laboratories Incorporated).

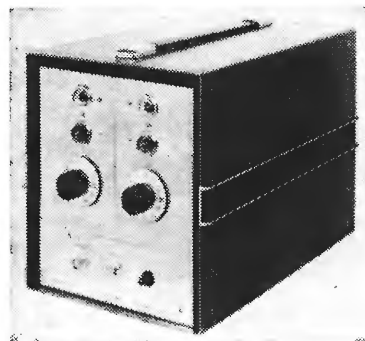

provided and facilities are incorporated for connection to 75 ohm aerial systems should it be required. The TR40/20 weighs 4 lb and measures 8 × 7 × 2 in.

A complementary low-power transmitter, Type TT40, using transistors is being developed for use with this receiver. Also under development is a combined portable transmitter-receiver, Type TRT/40, which will provide simple or duplex facilities.

2WW 320 for further details

### Metal-on-Oxide Transistor

A METAL-ON-OXIDE field effect device with a transfer conductance of 1 mho has been announced by the Raytheon Company. The device, known as the Mho-Amp (RM3036) has a low noise figure (2 dB at 1 kc/s with a generator impedance of 1 M $\Omega$ ) and is said to be extremely temperature stable. As an illustration of its application the transistor has been used as the only active element in an audio amplifier circuit providing a power gain of 70 dB and an output of 1 watt at 5% distortion.

2WW 321 for further details

### Transient Detector

AN instrument that can detect short-duration transients, quantize their amplitudes and determine their polarity, and provide an output suitable for driving counting and recording devices, is the Model 2601A transient detector from Huggins Laboratories Incorporated, of California, U.S.A. A number of input probes are available for this instrument and enable positive and negative transients of 50 nano-seconds and upwards to be measured. The voltage range of the instrument is from 100 mV to 5,000 V.

A feature of the Model 2601A is the inclusion of two threshold adjustment controls. These are calibrated directly in volts, one positive and the other negative, and once the pre-set level is exceeded neon indicators on the instrument light, an internal counter-relay operates, another relay operates and an oscilloscope trigger pulse is applied to the external sockets.

Other models which are also available from B & K Laboratories Ltd., of 4 Tilney Street, Park Lane, London, W.1, include the Type 2604 and the 2606. The first of these can accept up to four inputs, but with only one threshold control for each, and the other accepts up to six input probes and also has only one threshold control per probe. The input impedance of the probes, which cover the voltage range 100 mV to 5,000 V, increases with their voltage ratings from 1 M $\Omega$  to 100 M $\Omega$ .

2WW 322 for further details

# NATO V.L.F. STATION



## HIGH-POWER RADIOTELEGRAPH TRANSMITTER IN CUMBERLAND

**T**HE second of a series of four high-power v.l.f. stations to augment the communications facilities for the navies of NATO has been built on the coast of Cumberland and was brought into service at the end of November. The other station already in operation is at Cutler, Maine, U.S.A., and others will be in Australia and Italy. The site of the British station, for which the G.P.O. has been responsible for the building and will be for its future operation, is a 700-acre disused airfield between the villages of Anthorn and Cardurnock at the extremity of a peninsula on the Solway Firth. The use of v.l.f. is because of its reliability, it being unaffected by most ionospheric disturbances and nuclear explosions, and there are no "skip zones" as there are with higher frequencies relying on reflection from the ionosphere.

### Aerial System

A feature of the station is the aerial system, which consists of six rhombic-shaped sections arranged in a radial formation and suspended by 13 masts as shown in the diagram. The centre mast is 748ft tall, those in the inner ring 678ft and those on the periphery 618ft. The masts in the outer ring are 2,148ft from the centre. All six rhombics are fed simultaneously, giving a uniform polar diagram. The aerial is of steel-cored aluminium, about 1in in diameter, to enable it to withstand the working voltage of 120 kV without perceptible corona under adverse weather conditions and also be strong enough to withstand a heavy coating of ice.

An interesting aspect of the suspended

aerial system is the method adopted to prevent excessive tensions in the event of overloading due to ice or wind. The insulators at the four corners of each of the six aerial panels are attached to halyards which pass through sheaves at the mast heads and down to automatic winches on the ground. Each winch is fitted with upper- and lower-limit switches which allow the halyard to pay out when the tension reading reaches

the predetermined load of 31 tons. The loading is registered on a dial on the appropriate winch and relayed to 24 slave dials in the central control room.

The masts are of triangular cross section with solid round corner leg members, to minimize wind loading, braced together with a lattice framework. On each mast provision is made for the use of a self-climbing maintenance hoist operating on the rack and pinion prin-



*Insulator and corona ring assembly at the end of an aerial panel viewed from one of the 618-ft outer masts.*

ciple. The actual hoist cages are transportable so that it is not necessary to have one for each mast. Incidentally, calculations for the stayed mast structures were carried out by the sub-contractors, B.I.C. Construction Co., with the aid of the EDSAC2 computer at Cambridge University.

### Frequency Stability

The main contractors for the station were Continental Electronics Systems Inc., of Dallas, Texas, who received a fixed-price (10.5M dollars) contract in November 1961, and work began on the site in the following spring. Continental Electronics designed and built the transmitter which comprises a 250 mW drive stage, and at its normal working frequency of 19 kc/s is capable of delivering a peak power of 500 kW into the aerial. The transmitter is capable of keying speeds up to 50 bauds using frequency-shift or amplitude modulation. The frequency generator unit is installed in duplicate. If the normal frequency generator fails, the spare is automatically switched in in five milliseconds. The stability of the frequency generating equipment is within  $\pm 1$  part in  $10^{10}$  per day and  $\pm 1$  part in  $10^9$  per month. The output frequency can be set in steps of 100 c/s over the range 16-20 kc/s. The frequency synthesis and drive equipment was designed and manufactured by Redifon, of Crawley, who also constructed the station's control console. Redifon are associates of Continental

The position of the NATO v.l.f. station at Anthorn, Cumberland, is shown on this sketch map.

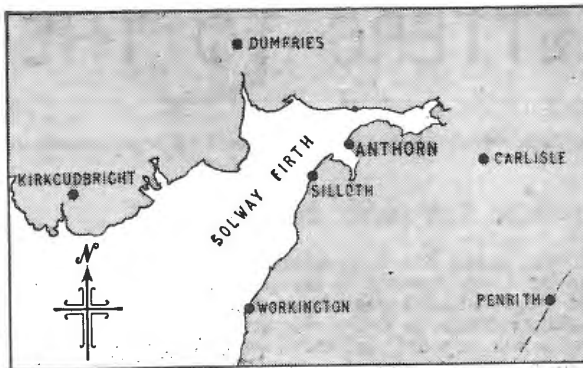

Electronics and provided the majority of the staff for the administration of the project and for the installation of the transmitting equipment.

The transmitter building, being at the centre of the aerial system, has been extensively screened against electrical losses and this screening is connected via a mesh of wires to the radial earth-wire system. This consists of 8 gauge copper wire laid radially at 2° intervals and at a depth of 1 foot. All joints have been welded to obviate bi-metallic corrosion. All metal work in the building is bonded to the earth system.

### Aerial Tuning

The aerial is resonated by a helical inductor nearly 20ft tall with an average winding diameter of 12ft. In series with this is an 18ft tall variometer with a 10ft

diameter stator and an 8ft diameter rotor. This variometer is used for tuning over the range 16-20 kc/s and a smaller variometer automatically adjusts aerial capacitance to changes in the aerial system caused by weather conditions. Both variometers are motor-driven and are remotely controlled from the operating console. Both variometers and also the helix are wound with Litz cable 3.4in in diameter.

The radio-frequency valves are air-cooled and the mercury vapour high-voltage rectifier valves are provided with overload protection equipment which will operate to remove power from the transmitter in about 5 microseconds. To avoid interruption due to failure of valves or other equipment the transmitter is built of duplicate 275 kW sections which can be worked individually or in parallel.

The tank-circuit for the output stage of each half of the transmitter comprises a fixed inductor of toroidal form connected in parallel with aluminium plate variable oil-filled capacitors. Inductive coupling is used with a pick-up loop through the centre of the toroid. Coupling to the aerial-circuit is effected via matching networks which enable the aerial to be energized by either or both halves of the transmitter.

The power supply for the station is normally taken from the mains but two 600 kW generators have been installed for emergency use by the English Electric Company (who were also responsible for the electrical sub-station). Each of these generators, which can be started remotely from the main transmitter console, is connected so as to supply independently one half of the transmitter and miscellaneous loads.

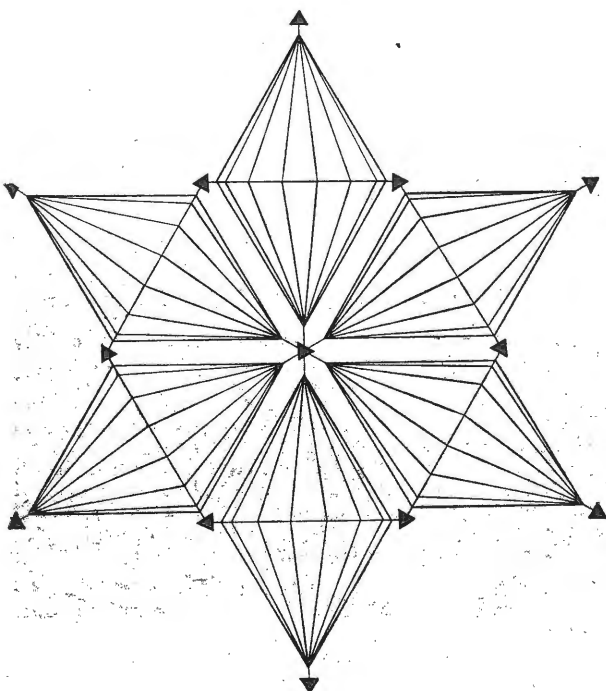

The layout of the six rhombic-shaped sections of the aerial which is suspended from thirteen stayed triangular towers. Anthorn has the largest aerial system in Europe the distance between two opposite points of the "star" being nearly a mile.

Our cover photograph shows the feeder from the transmission building to the aerial distributor ring suspended around the central mast at a height of some 120ft.

# LETTERS TO THE EDITOR

The Editor does not necessarily endorse opinions expressed by his correspondents

## Transistor High-quality Audio Amplifier

Referring to Mr. Dinsdale's article on his improved transistor amplifier, I was interested in his opinions on the avoidance of earth loops and asymmetrical currents.

Whilst it cannot be denied that these problems exist, I feel that his two proposed methods of avoidance are not the only methods.

His suggestion of two separate power packs is, of course, the academic way of solving the problem, but from the point of view of manufacture, prohibitive on expenditure. Also, his alternative method, as used in this design, causes some distortion on mono reproduction, as he states.

Having been in the course of design of high-quality amplifiers for the past year, I have some experience and would therefore like to bring to the attention of the author a method which I have found to be most satisfactory.

It is only necessary to prevent these currents from flowing in the earlier stages of both amplifiers and the attached sketch

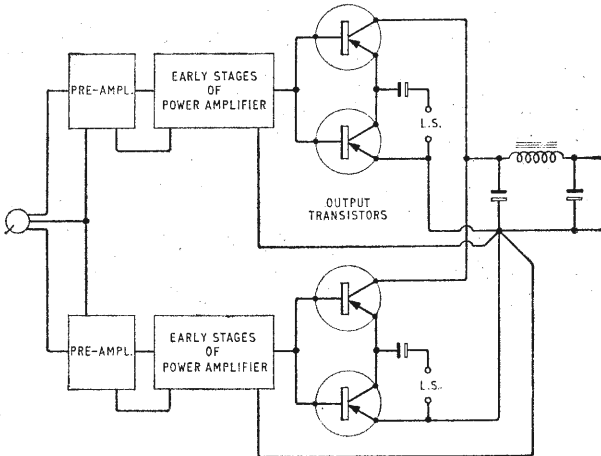

outlines my method which entails running four separate earth lines from the smoothing capacitor. As will be seen, no common impedance path now exists, the smoothing capacitor being true a.c. earth.

London, S.W.8. C. ARTUS,  
Radio Laboratory, Decca Radio & Television.

The author replies:—

I was very interested to see the solution proposed by Mr. Artus, since this seems almost ideal. The even-harmonic distortion signal is now developed across the earth leads to the two sections of the power amplifier and is in fact within the main feedback loop as I originally suggested, but without the undesirable high resistance of 10 ohms.

Furthermore this solution is easily utilized with the printed circuit design proposed, by taking the additional earth lead from one side of  $R_{18}$  (which is of course omitted). In the practical design described I suggest that the power plug should be made at least 8-way to accommodate the additional leads.

J. DINSDALE

I FOUND the article "Transistor High Quality Audio Amplifier" by J. Dinsdale in your January issue most interesting, as I recently built the original amplifier, and have now

carried out the modifications put forward, with very pleasing results.

However, I am puzzled by two points. In an appendix, Mr. Dinsdale calculates the dependence of channel separation in a sum-and-difference type of pickup on load. My own calculations give a rather different result, although the conclusions are the same.

Referring to the circuit shown in the appendix, and using the same symbols, but putting  $Z_V + Z_H + R = X_c$ , the two currents,  $i_L$  and  $i_R$  are given by

$$i_L X_c - i_R Z_H = e_H - e_V \dots \dots \dots (1)$$

$$\text{and } -i_L Z_H + i_R X_c = e_H - e_V \dots \dots \dots (2)$$

(1) and (2) lead to

$$i_L = \frac{e_H}{X_c - Z_H} - \frac{e_V}{X_c + Z_H} \dots \dots \dots (3)$$

$$i_R = \frac{e_H}{X_c - Z_H} + \frac{e_V}{X_c - Z_H} \dots \dots \dots (4)$$

Assuming that

$e_H = e_R + e_I$ , i.e., the sum of the two channel signals,

and

$e_V = e_R - e_I$ , the difference between them,

then 3 and 4 become

$$i_L = \frac{2X_c}{X_c^2 - Z_H^2} \cdot e_L + \frac{2Z_H}{X_c^2 - Z_H^2} \cdot e_R$$

and

$$i_R = \frac{2X_c}{X_c^2 - Z_H^2} \cdot e_R + \frac{2Z_H}{X_c^2 - Z_H^2} \cdot e_L$$

giving

$$E_L = i_L \cdot R = \frac{R}{X_c^2 - Z_H^2} (2 \cdot X_c \cdot e_L + 2 \cdot Z_H \cdot e_R) \dots (5)$$

and

$$E_R = i_R \cdot R = \frac{R}{X_c^2 - Z_H^2} (2 \cdot X_c \cdot e_R + 2 \cdot Z_H \cdot e_L) \dots (6)$$

I am not entirely clear from Mr. Dinsdale's equations what definition of channel separation is being used. However, I take it to be the ratio of signal from the required channel to the signal from the unwanted channel in either of the two outputs. This ratio, from (5) and (6) above, is given by:—

$$\text{Channel separation} = \frac{X_c}{Z_H} = \frac{Z_V + Z_H + R}{Z_H} \\ = \frac{R}{Z_H} \text{ for } R \text{ large compared with } Z_V + Z_H$$

It follows that for good separation, R should be as large as possible.

In fact, I think this conclusion can be reached more quickly without resorting to these calculations. When R is an open-circuit, or very high, the voltage  $E_L$  equals  $e_H - e_V = e_I$ . As R is lowered, so that significant current flows, the current carrying information for one channel will clearly generate a signal in the other output through the common impedance  $Z_H$ . Assuming that R is still large compared with  $Z_H + Z_V$ , then the output in, say, the left-hand channel is  $i_L \cdot R$ , and the cross-coupled signal into the right-hand channel is approximately  $i_L \cdot Z_H$ .

The separation is then, as before,  $\frac{R}{Z_H}$ .

The second point is concerned with the value of  $R_8$  in the pre-amplifier. Was this intended to be printed as 22kΩ rather than 22Ω? A value of 22kΩ yields a calculated total

\*With apologies, yes.—Ed.

current drain from a 12 volt supply of 2.7 mA (Mr. Dinsdale's figure for the total current drain is also 2.7 mA), whereas 22Ω leads to a figure of 3.3 mA. 22Ω also removes all gain from the amplifier! The capacitor  $C_1$  is given as 200μF, a value more suited to decoupling 22kΩ than 22kΩ. Its voltage rating, 6 volts, would also be exceeded if  $R_8$  were made 22kΩ. Were the value and rating of  $C_1$  calculated on the basis of  $R_8 = 22Ω$ ?  
London, N.W.3. S. C. RYDER-SMITH

*The author replies:—*

I am most grateful to Mr. Ryder-Smith for pointing out the error in my derivation of channel separation. I inadvertently overlooked one of the cross-coupling terms, and failed to spot this on subsequent re-reading. Mr. Ryder-Smith's figures appear to be correct, and the conclusions support results obtained in practice.

The correct value of  $R_8$  should be 22kΩ. The value of  $C_1$  is large to avoid feedback via the supply line; the time constant of 2 seconds ( $C_1$  and  $R_{11}$ ) successfully prevents very low frequency oscillation to which this circuit would otherwise be prone due to the very high power gain. The working voltage of  $C_1$  is about 5.5. I would point out that  $R_{28}$  and  $R_{29}$  should be taken from the left hand side of  $R_{26}$ , not as shown in Fig. 2. The printed circuit is correct.

J. DINSDALE

### Television Distribution by Wire

I SHOULD like to reply to some of the points made by Mr. Young in your issue of January (p. 41).

I agree with Mr. Young that it is a pity that in the space of such a short article it is not possible to go into all the technical matters in as much detail as one would like but I did provide fifteen references in the bibliography (several of which are devoted to v.h.f. systems) which should fill in at least some of the gaps. I do not, however, agree with Mr. Young's contention that my article has "deviated into the realms of relay politics": certainly I have mentioned some of the basic cost factors which influence the choice between an h.f. and a v.h.f. system, but I make no apology for this as I feel it is a great pity that articles written on technical matters often fail to make it clear to the non-specialist reader what was the economic reason that prompted the design of the equipment in the first instance.

Mr. Young feels that I have dealt too briefly with the v.h.f. system in comparison with the h.f. system but I should explain that one of the reasons which prompted me to write the article in the first instance was the fact that more has been published about v.h.f. systems than about h.f. systems and I felt it was time to redress the balance.

I am surprised that Mr. Young should think that h.f. relay networks were only born in order to avoid the "financial ruin of old audio-only networks." I thought I had made it abundantly clear that unscreened quad cable as used on audio systems could not be used to distribute television signals (see Fig. 10, p. 501, Oct. 1964 issue). Thus some new type of cable had to be added to existing audio networks in any case and, were it not for the economic advantage of an h.f. system, it would have been just as easy to have added coaxial rather than special balanced pair cable to existing networks. However, the special balanced pair cable is capable of carrying audio at sufficient power to energize loudspeakers in private homes directly and since this is the cheapest way of distributing audio programmes, coupled with the fact that the same pairs could also carry television signals at h.f., these were the factors which influenced the decision to use h.f. rather than v.h.f. for the television signals. If further proof is needed, plenty of new h.f. systems have been started in towns where no wire previously existed.

I am, of course, well aware of the use of v.h.f. systems in Europe and North America but why should Mr. Young assume that this places these countries ahead of the United Kingdom? In point of fact, in the U.S.A., only v.h.f. systems are used and only 1.9% of TV homes received their signals by wire at the end of 1963. In the U.K. the corresponding figures were 1.65% by v.h.f. and 4.4% by h.f. making a total of 6.05%. Mr. Young is worried about what happens to the purchaser

of a wired receiver when he decides to move house. Most wired receivers are, in fact, hired rather than sold which is also the trend for aerial receivers, so there is no problem. If, however, a wired receiver is purchased it can always be sold back to the local operating company.

Mr. Young is worried about the effect of breakdowns on the network but he should bear in mind that a fault on a coaxial system might well lead to a loss of all the programmes whereas a fault on a multipair h.f. system might only lead to the loss of one programme. In the case of a complete cable rupture, I quite agree that a subscriber of an aerial receiver could receive something, but how many subscribers to v.h.f. systems (which more often than not are in fringe areas) would want to maintain Band I, Band III and Band V aeriels in working order all the year round just to be able to deal with occasional breakdowns?

R. I. KINROSS

### "Units"

MUCH as I admire "Cathode Ray's" illumination of basic matters, I feel I must protest against his propagation of some hardy old fallacies in his article in last month's *Wireless World*. To be brief, the most important question is his statement that "the ratio of two quantities of the same kind *must* be a pure number, with no dimensions." This seems so obvious that we do not pause to examine it, but its truth depends on the meaning of "quantities of the same kind", and if we wish the statement to be true, we may decide that the electrostatic and electromagnetic measures of charge are not quantities of the same kind.

A return to "Cathode Ray's" example of sugar may help here. If I have a packet of sugar, I may estimate the quantity of sugar by weighing, thus determining its mass, or by measuring the packet, thus determining its volume. These are different operations, and I would not normally expect to equate the dimensions of the quantities obtained, though they are, both measures of the quantity of sugar. I could equate them, however, by introducing a dimensional "constant", the density of sugar, into one of the equations defining the "mass" or the "volume" in terms of the physically measured quantities. In a similar way, I may estimate electrical charges by measuring the electrostatic forces between them, or by moving them (spinning them round, for example) and measuring the magnetic forces. There need be no astonishment that the definitions of quantity of charge resulting from these procedures do not have the same dimensions. Again I may prefer to introduce one or more dimensional constants in the definitions in order to make the dimensions the same, and these constants will embody a property of electricity, namely the velocity of electromagnetic waves. This procedure is sometimes adopted electrically, I suggest, only because the wave velocity appears to be such a universal and reliable constant, whereas the density of sugar is probably not, and we also have other substances of different densities.

I should also like to comment on the statement presumably intended to read "nobody knows what the dimensions of  $\epsilon$  and  $\mu$  are." While this is true, it seems to imply that  $\epsilon$  and  $\mu$  possess (separately) certain dimensions, which experiment or theory may one day determine. This gives an air of mystery to the matter which is quite unwarranted; all that has happened is that we have introduced two dimensional constants instead of only the one which is required to make the definitions of electrostatic and electromagnetic charge dimensionally equal.

Thus I disagree that electrical quantities cannot be expressed in terms of mechanical ones, or that the c.g.s. system is fundamentally unsound. Much disagreement on matters of units and dimensions might be avoided if their largely arbitrary nature were more generally realised. The case for m.k.s.A. or other systems can be argued on grounds of convenience, but not from logical necessity. As for the idea that c.g.s. units are rapidly being consigned to past history, I think a glance at a few scientific papers will show that that is hardly the case.

Bristol.

D. F. GIBBS

*The author replies:—*

It is remarkable the lengths to which people will go in order to avoid change. I have recently been much impressed

by this in quite a different field (see correspondence under the heading "A new deal for vector diagrams" in many of the 1964 issues of the I.E.E. journal, *Electronics and Power*) in which some normally intelligent people have averted their gaze from the abhorred thing that would call for change in their habits and on that inadequate basis have made untenable criticisms of it.

Coming to "Units", Mr. Gibbs accuses me of propagating "some hardy old fallacies", which of course he is quite entitled to do if he can substantiate the charges. As an example of his own clarity of thought he has introduced a term "quantity" of sugar, by which he seeks to persuade us that the term "electric charge" comprises two dimensionally different quantities, measured in e.s.u. and e.m.u. respectively. But in doing this he uses "quantity" loosely and unscientifically to include two quantities that are clearly not of the same kind and which occasion no surprise when they turn out to have different dimensions. Electric charge, on the other hand, is surely the same kind of thing no matter how it is measured. There are many different ways of measuring volume, for example, but any method that gave it dimensions other than  $L^3$  would have to be looked at rather carefully. (Still more so if they appeared with fractional indices, like the c.g.s. units of electrical quantities!) Even if volume is arrived at via mass and density it is still  $L^3$ . The question of greater or less reliability or constancy as between the density of sugar and the velocity of electromagnetic waves has nothing to do with the principle.

If Mr. Gibbs has discovered that electrical units can be expressed in terms of mechanical units only, in contradiction to Maxwell and many more modern authorities, he ought to tell us what they are, or is he too modest to risk the fame that would accrue?

If I "seem to imply that  $\epsilon$  and  $\mu$  possess (separately) certain dimensions", why should Mr. Gibbs object, when he himself in the next sentence says they are dimensional?

My evidence that c.g.s. units are rapidly being consigned to past history is the fact that nearly all the books on electrical engineering on both sides of the Atlantic written in the few years since m.k.s.A. units were officially approved have adopted them, and—more surprisingly—that they have been adopted to a notable extent by physicists in books and University departments. I have already referred to those who are unwilling to make the effort to change from the familiar to the unfamiliar, and who even seek to defend this inertia by a show of argument. But this can only delay, not prevent, the change.

"CATHODE RAY"

## Resistance and Reactances in Parallel

YOUR correspondent in the January issue correctly assumes that the construction for parallel resistances and reactances is not novel. The earliest reference to it appears to be E. Orlich, *Archiv für Elektrotechnik*, Vol. 8, 1919, p. 187. It is referred to again by H. Rukop in the same journal, p. 446, 1929. More recent references include E. W. Bochner, *I.E.E.E. Transactions*, July 1963, and a note by myself, *Proc. I.E.E.*, Vol. 111, No. 2, February 1964.

I agree with your correspondent's view of the educational benefit of the construction and this is demonstrated in the two latter articles by its use in the solution of other problems.

Aberdeen

E. WILKINSON

Robert Gordon's Technical College

If Mr. de Visme is able to inspect a copy of Vol. 2 of *Experimental Wireless and The Wireless Engineer*, he will find in the Dec. 1924 issue, p.143, a method, identical to his own and including the case of LCR in parallel, expounded by F. M. Colebrook. Anybody intending to use these methods for any but the simplest cases say, to solve a ladder network, is advised to start with an outsize sheet of paper and several coloured pencils.

Graphical methods of this kind are also covered in "Continuous Wave Wireless Telegraphy" (1921) by Dr. W. H. Eccles but the more complex examples in this book are drawn in a confusing manner.

It is interesting to note the frequency with which the "wheel" tends to be reinvented as one generation of engineers fade out and the new boys take over. A recent example of this was the screen coupled circuit discussed in letters in the Feb. and March 1964 issues of *W.W.* This arrangement was used by Du Mont in their Model 208 oscilloscope brought out about 1940. Certain U.S.A. literature at the time described the relevant part of the circuit as cathode coupled but 90% of the coupling was via the common screen resistor.

Another example is the cascade or White cathode follower circuit which has been treated as a new circuit in several technical journals in recent years. This arrangement was used in the Mk3 or Mk4 A.I. radar sets, also dating back to around 1940.

Blackburn.

R. S. HATCH

## Information Storage and Retrieval

HOW very reassuring to see in the January issue so sane an editorial on this subject!

Omitting the fact that it is often cheaper and quicker to find something out in the lab. than to make a search for the information, there are two fundamental difficulties here which are rarely considered. The first is that in many areas of science, the information obtained by university people is virtually useless for industrial purposes: it is expressed, too, in a shorthand or jargon which is comprehensible to few outside the charmed academic circle. The reverse may also be true, but since very few academic scientists are even interested in industrial matters, relatively little damage is done.

The second point is that when one makes a search, one is usually looking for something—such as a line of thought—which is *not* present explicitly, but may be fitfully and faintly suggested in terms which would mean nothing at all to an abstractor.

Now that techniques are overlapping each other so very much more than they once did, a file in some central office indicating what every firm in the country was actually doing or producing would be far more help than any centralized information service. Nobody can advertise in all the journals all the time, especially those firms which are small and rather specialized in function.

Bolton, Lancs.

P. C. SMETHURST

## CLUB NEWS

**BIRMINGHAM.**—The February programme of the Slade Radio Society includes a Mullard film show on the 25th which will be held in the Great Hall of the College of Advanced Technology, Gosta Green, at 7.30.

**DERBY.**—"The short-wave listener" is the title of the talk to be given by B. J. C. Brown (G3JFD) at the meeting of the Derby & District Amateur Radio Society on February 10th. At the February 24th meeting M. Shardlow and J. Anthony will give a technical film show. Weekly meetings are held at 7.30 at 119 Green Lane.

**HECKMONDWIKE.**—The month's meetings of the Spen Valley Amateur Radio Society include a lecture on model control by F. Sharpe, of the Leeds Model Boat Society, on the 4th and a lecture on radio-active isotopes in every-day life by J. A. Edwards, of Research Electronics, on the 18th. Fortnightly meetings are held at 7.30 at the Grammar School, High Street.

**LEAMINGTON.**—Fortnightly meetings of the Mid-Warwickshire Amateur Radio Society are held in the Civil Defence Training School, Harrington House, Newbold Terrace, at 7.45 on alternate Mondays. At the meeting on February 22nd the third in a series of lectures on radio theory will deal with valves and transistors.

**WELLINGBOROUGH.**—Two lectures on hi-fi are to be given this month to members of the Wellingborough Radio Club by D. Clarke. On the 11th he will deal with fundamentals of hi-fi and on the 18th with home-made equipment. Weekly meetings are held at 7.45 at Silver Street Club Room.



# WORLD OF WIRELESS

## Electronics Industry Enquiry

A DETAILED study on the extent and causes of the import of electronic products into the U.K. with a view to "improving the present balance of trade in electronics" is being undertaken by the Economic Development Committee for the Electronics Industry. This is one of several "little Neddies" set up by the National Economic Development Council to look into various branches of industry. Mr. George Brown, the First Secretary of State, who is also chairman of N.E.D.C., recently met Sir Edward Playfair, the chairman of the Electronics E.D.C., because of criticisms of its effectiveness. It is felt by some members of industry that there is likely to be confusion and overlapping between the electronics "little Neddy" and the committee for the electronics industry proposed by the new Ministry of Technology which is now the "sponsoring" department for the industry.

The twelve members of the Electronics E.D.C. include J. Duckworth, managing director, National Research Development Corp.; W. D. H. Gregson, general manager, Ferranti; C. A. W. Harmer, deputy chairman, Pye; Dr. G. G. MacFarlane, director, Royal Radar Establishment; R. Telford, director and general manager, Marconi Company; and A. Weinstock, chairman, G.E.C.

## Transistor Patent Litigation

A CLAIM by three American companies—Western Electric, Bell Telephone Laboratories and American Telephone and Telegraph—to extend the period of the patent (No. 694,021) covering "apparatus employing bodies of semiconducting material" was rejected by Mr. Justice Lloyd-Jacob in a reserved judgment in the High Court on January 11th. The application, which was heard in the Chancery Division before Christmas, was opposed by a number of British companies\* led by Pye of Cambridge. The judgment concerns the patent covering the original transistor but not the many subsequent patents covering developments resulting in later devices.

\* Avo, Dawe Instruments, Decca, Electronic Instruments, Farnell Instruments, International Computers and Tabulators, James Scott (Electronic Engineers), Muirhead and Co., Rank Precision Industries, Wayne Kerr Laboratories, W. H. Saunders (Electronics) and W. Mackie.

## More B.B.C. Stations

THE Postmaster-General has approved in principle the B.B.C.'s plans for building a further 19 low-power relay stations to extend and improve the coverage of the 405-line television service and its v.h.f. sound services. The stations will be in general use "translators" which receive the transmissions from an existing station and relay them on another channel.

Under these plans (Stage 4) relay stations for both television and v.h.f. sound will be built in the Scilly Isles, and at Campbeltown, Argyll; Kingussie, Inverness; Lochgilphead, Argyll; Dolgellau, Merioneth; Llanidloes, Montgomery; Ballycastle, Mayo; and Killeel, Down. Stations for television only will be at Aldeburgh, Suffolk; Bodmin, Cornwall; Bude, Cornwall; Whitby, Yorks; Ayr; Ballater, Aberdeen; Girvan, Ayr; Cardigan, Portrush, Antrim; and at Llangollen, Denbigh, where a v.h.f. sound transmitter is already in use. A relay station for v.h.f. sound will be added at Weardale where a television transmitter is being built under Stage 3.

With the completion of Stage 4 in about the middle of 1966 the total number of relay stations built by the B.B.C. will have reached 66 for television and 48 for v.h.f. sound. The nominal coverage of BBC-1 will then be 99.5 per cent of the population and that of the v.h.f. sound service 99.7 per cent. So far 27 television stations and 16 v.h.f. sound stations have been brought into service.

## New Year Honours

AMONG the recipients of awards in the New Year Honours List are the following in the world of radio and electronics.

### K.B.E.

Instructor Rear-Admiral Charles Roy Darlington, B.Sc., A.M.I.E.R.E., director, Naval Education Service.

### C.B.E.

R. D'A. Marriott, D.F.C., assistant director of sound broadcasting, B.B.C.

F. J. E. Tearle, B.Sc.Tech., managing director, A.E.I. (Overseas) Ltd.

### O.B.E.

D. A. Lightfoot, director, Northern Rhodesia Broadcasting Corporation.

C. L. Page, assistant controller, television administration, B.B.C.

J. H. Pinkerton, lately controller of telecommunications, Penang, Malaysia.

J. G. Preston, lately controller of telecommunications (traffic), Malaysia.

W. J. E. Tobin, B.Sc., A.C.G.I., D.I.C., A.M.I.E.E., staff engineer, G.P.O.

Lt. Col. J. Vevers, M.I.E.R.E., Corps. of R.E.M.E.

### M.B.E.

S. G. Bishop, senior experimental officer, Signals Research & Development Establishment.

V. J. Cox, B.E.M., chief development engineer, Aviation Division, Ekco Electronics.

W. Hogg, production superintendent, Sperry Gyroscope Co., Stonehouse, Glos.

F. J. F. Properjohans, A.M.I.E.R.E., electrical inspectorate, Ministry of Aviation.

A. E. Robertson, B.Sc., A.M.I.E.E., head of engineering training dept., B.B.C.

E. J. T. Symonds, assistant director (engineering), Postmaster-General's Dept., South Australia.

J. C. Walling, Ph.D., senior physicist, low-temperature physics, Mullard Research Laboratories.

A. J. Woodward, works manager, electronics dept., Ferranti Ltd., Hollingwood, Lancs.

### B.E.M.

R. S. James, laboratory mechanic, D.S.I.R., Radio Research Station, Slough.

A. W. Morgan, foreman, G.E.C. Telecommunications, Middlesbrough.

## P.C.M. for G.P.O. Telephones

A TEN-FOLD increase in the capacity of existing short-distance speech channels (up to 25 miles) between telephone exchanges may soon be achieved by the use of pulse-code modulation by the Post Office telephone service. The G.P.O. is at present conducting field trials of the system on a cable route between Guildford and Haslemere, Surrey. Using coding and decoding equipment built by Standard Telephones and Cables, the four-wire cable can now handle 23 instead of the normal two conversations—one pair of wires carrying the "go" channels and the other pair the "return" channels. *Wireless World* was invited to take part in comparative tests and could detect no deterioration of speech quality from that of normal transmission—the only noticeable difference being the absence of background noise.

This method of transmission, which incorporates the principle of time division multiplex, was devised in 1937 by

A. H. Reeves, of Standard Telecommunication Laboratories. Only recently, however, has it become economic for telephone services (through the advent of low-cost transistors) and it is now being widely used in the U.S.A. For long-distance communication, frequency multiplexing is the more economic system.

In the Guildford-Haslemere equipment, the speech waveforms are sampled in sequence at a rate of 8,000 samples per second and each sample is quantized to one of 125 voltage levels. Each quantized sample level is then signalled to the receiving end by a train of eight binary digit pulses. This requires a bandwidth of about 1.5 Mc/s. The transmitted pulses are regenerated by transistor repeaters inserted at intervals of 2,000 yards along the cable and again at the receiving end where the speech waveforms are reconstructed.

**Pilot-tone Stereo Tests.**—Technical details and the schedule of tone transmissions being radiated during the new series of stereo tests introduced by the B.B.C. on December 15th are given in Information Sheet 1602 available from the Engineering Information Department, Broadcasting House, London, W.1. The Zenith-GE (pilot-tone) transmissions are radiated from Wrotham, Kent, on 91.3 Mc/s on Tuesdays, Wednesdays and Thursdays from 1430-1500 and from 1515-1545.

**Colour transmissions,** using the 625-line N.T.S.C. system, from Crystal Palace (Channel 33) were resumed by the B.B.C. on January 18th. The schedule is: Tuesday to Friday 1600-1630 colour bar and slides with possibly a film on Fridays; Tuesday and Thursday films and occasionally live pictures from the studio will be radiated for about an hour from the close-down of BBC-2, but not after midnight. Notes on the transmissions are given on Information Sheet 4201 obtainable from the Engineering Information Dept. of the B.B.C.

The evolution of cathode-ray tubes for television, the reasons for each major stage of development over the past 25 years and, in simplified form, the associated electron-optics are given in "Electrons in Picture Tubes" the fifth in the Mazda series of "Electron" educational booklets. This 24-page booklet written by B. Eastwood, chief engineer of the Thorn-AEI Applications Laboratory, is intended for the apprentice technician level and is obtainable free from Thorn-AEI Radio Valves & Tubes Ltd., 155 Charing Cross Rd., London, W.C.2.

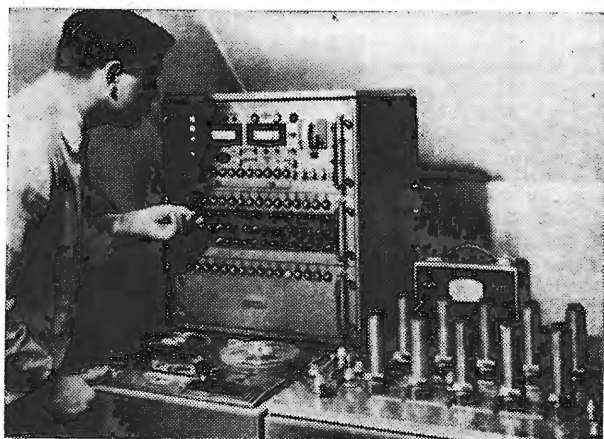

**Test Tape Production.**—For the automatic production of frequency test tapes for magnetic reproducers, Telefunken have developed a punched-tape controlled system comprising a Magnetophon 24 recorder, a programmed oscillator amplifier and (on the right) a series of vertical print rollers which mark the relevant frequencies on the back of the tape.

## "WIRELESS WORLD" INDEX

The Index to Volume 70 (1964) is now available price 1s (postage 3d). Cloth binding cases with index cost 9s, including postage and packing. Our publishers will undertake the binding of readers' issues, the cost being 30s per volume including binding case, index and return postage. Copies should be sent to Associated Iliffe Press Ltd., Binding Department, c/o 4 Iliffe Yard, London, S.E.17, with a note of the sender's name and address. A separate note, confirming despatch, together with remittance should be sent to Dorset House, Stamford Street, London, S.E.1.

The first European conference on magnetism is to take place in the Technischen Hochschule, Vienna, from the 21st to 24th September. The conference secretariat is Verein Deutscher Eisenhüttenleute, 4 Düsseldorf, Breite Strasse 27, from whom registration forms and further details are available.

An Instrument Industry Conference is being organized by the British Scientific Instrument Research Association and will be held at the Grand Hotel, Eastbourne, on May 13th & 14th. It will be concerned with new materials and processes in instrument manufacture. Registration forms and the conference programme are not yet available but provisional bookings can be made through Miss A. E. S. Mills, B.S.I.R.A., South Hill, Chislehurst, Kent.

A new hall, with a display area of about 75,000 sq ft, is being built at the site of the Hanover Fair to accommodate the electronics section which has grown considerably. Applications have been received from nearly 500 manufacturers of electronic equipment to participate in this year's show—April 24th to May 2nd. The London agents are Schenkers Ltd., 13 Finsbury Square, E.C.2.

Micro-circuit welding techniques are being demonstrated at the factory of Hirst Electronic Ltd., Gatwick Rd., Crawley, Sussex, for two weeks commencing 8th February. Hirst, who are the U.K. distributors for the precision micro-welders manufactured by the Hughes Aircraft Company, of California, will be pleased to send invitation cards to interested engineers.

Special courses during the Spring Term at Hendon College of Technology include one on logic algebra and its application to systems design comprising seven weekly evening lectures beginning February 16th (fee 50s). A practical transistor course of six laboratory sessions begins on March 3rd (fee 35s). There is also a six-lecture course on television, covering both 625-line and colour, which starts on January 28th (fee 20s).

**A Museum Piece!**—The first Leo computer, which was produced by J. Lyons & Co., the caterers, and has been in use since February 1951, was finally switched off on January 4th. It has been used by Government Departments as well as by many commercial companies. Parts of this historic computer, which contains more than 7,000 valves and a half a ton of mercury in its store, will be given to the Science Museum.

## Errata

"Miniature Selenium Rectifiers". — On page 19 of this article in the January issue the right-hand side of the first equation should start =  $\frac{1}{r}$ . In the fifth expression in this column for  $\cos^2 \pi t$  read  $\cos^2 \theta t$  and near the bottom  $\frac{T^2}{2}$  should read  $\frac{T^2}{2}$ . On page 22, first column,  $\gamma$  which appears in three places should be  $r$ .

# PERSONALITIES

**F. Neil Sutherland, C.B.E., M.A., M.I.E.E.**, has accepted the invitation to become president of the Television Society in succession to **Sir Robert Fraser** who has held the office for the past two years. Mr. Sutherland became general manager of the Marconi Company when in 1946 it became a member of the English Electric Group which he joined in 1922 after graduating at Cambridge. In 1958 he became managing director of Marconi's and four years later also deputy chairman of both the Marconi Company and Marconi Instruments. Mr. Sutherland has been one of the radio industry's representatives on the Postmaster-General's Television Advisory Committee for the past two years, is president of the Electronic Engineering Association, and also vice-chairman of the Conference of the Electronics Industry.

**B. N. MacLarty, O.B.E., M.I.E.E.**, has retired from the Marconi Company which he originally joined in 1921. He was one of the team of engineers who, with Capt. P. P. Eckersley, set up the experimental station 2MT, in Writtle, near Chelmsford, from which this



B. N. MacLarty

country's first regular broadcasts were made early in 1922. In 1926 Mr. MacLarty joined the B.B.C. Research Department and was head of the Design and Installation Department when he left in 1947 to return to Marconi's as deputy engineer-in-chief. Seven years later he became engineer-in-chief and for the past two years has been engineering consultant to the company.

**S. N. Watson, M.I.E.E.**, head of the designs department of the B.B.C.'s Engineering Division for the past year, has been elected president of the British Amateur Television Club. He succeeds **G. B. Townsend, B.Sc., A.K.C., M.I.E.E.**, who has served for the past four years.

**Trevor S. Chatfield**, general manager of Hughes International (U.K.), Ltd., of Glenrothes, Fife, Scotland, has been appointed to the board of directors but will continue as general manager. Mr. Chatfield, who is 31 and has been with Hughes International (U.K.) since June 1960, joined as production manager. A year later he was promoted to works manager, and a year after that he became general manager. He spent the early part of his career in the metallurgical laboratories of the English Electric Company's Nelson Research Laboratories on the development of semiconductor materials.

**J. P. Atkins, A.M.I.E.R.E.**, has become engineer-in-charge of the B.B.C.'s Brookmans Park, London, transmitting station, in succession to **N. G. L. Wilkins**, who has retired. Mr. Wilkins joined the B.B.C. in 1926 as an assistant maintenance engineer. In 1947 he became assistant engineer-in-charge at Brookmans Park, where he was appointed engineer-in-charge in 1959. Mr. Atkins joined the B.B.C. in 1937 and after service as a senior maintenance engineer at a number of transmitting stations he was appointed assistant engineer-in-charge at Brookmans Park three years ago.

**A. G. W. Wilson** has been made technical manager of Mullard Overseas Ltd. and will be responsible in overseas markets for the technical aspects of the Mullard range of valves, tubes, semiconductors and other components. Mr. Wilson, who was formerly in the B.B.C. Research Department joined Mullard in 1948. Mullard Overseas also announce the appointment of **D. A. Bolton** as commercial manager and **G. H. Tuppen** as administrative manager. Mr. Tuppen, who has been with the company for 38 years, was for some time supervisor of the Service Department.



A. G. W. Wilson

**J. C. Walling, Ph.D.**, who is appointed an M.B.E. in the New Year Honours List, was leader of the team at Mullard Research Laboratories which designed and built the maser amplifier for the



Dr J. C. Walling

Goonhilly Down satellite station. Dr. Walling, who obtained his Ph.D. degree at Leeds University for work on low temperature physics, joined Mullard Research Laboratories in 1952. After working for four years on travelling-wave amplifiers he resumed his work on low-temperature physics and in particular travelling-wave masers. He is 36.

**John H. Jupe, A.M.I.E.E.**, has joined the Research Division of English Electric-Leo-Marconi Computers at North Acton as technical editor. Except for a few months in 1952 when he was in Marconi's Technical Information Division, Mr. Jupe had been with the G.E.C. since 1947. He was for some years press officer but latterly had been technical information officer.

**John R. Hearn, B.Sc., Grad.Inst.P.**, who joined Hewlett-Packard Ltd. three years ago as a research and development engineer, has been appointed chief engineer. He is 29. A graduate of Southampton University, where he read physics, Mr. Hearn was for six years with de Havillands working on the design and development of transducers and strain gauge telemetry equipment before joining Hewlett-Packard.

The B.B.C. announces the appointment of **H. Henderson, B.Sc.(Hons.), A.Inst.P., A.M.I.E.E.**, as head of the Engineering Training Department at Evesham in succession to **A. E. Robertson, B.Sc.(Eng.), A.M.I.E.E.**, who is retiring in April. Mr. Robertson took his degree in electrical engineering at the University of Glasgow and, after several years in industry, joined the B.B.C. as an assistant maintenance

engineer in Glasgow in 1936. He became chief instructor at the Engineering Training Department in 1946, was appointed assistant head in 1948 and has been head since March, 1964. Mr. Robertson was appointed an M.B.E. in the New Year Honours List. Mr. Henderson graduated at University College, London, in 1942 and for three years served as an experimental officer with the Admiralty, where he was engaged on radar receiver research and design. He then taught in London and Leeds before joining the B.B.C. Engineering Training Department in 1952 and has been senior lecturer in the fundamentals section since 1954.

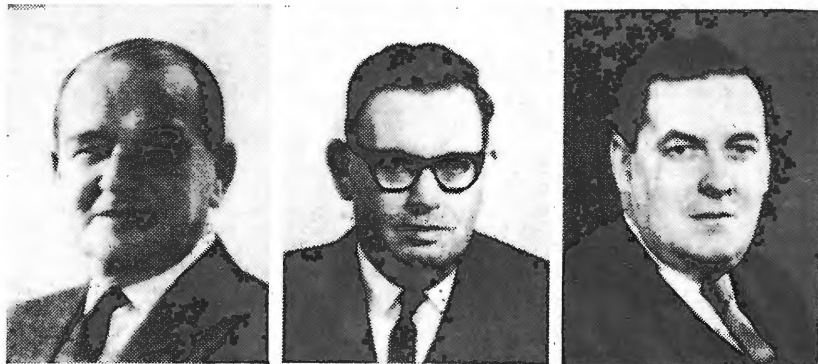

J. Ayres

R. J. Clayton

T. C. Standeven

**W. Cawood, C.B., C.B.E., B.Sc., Ph.D.**, recently appointed chief scientist in the Ministry of Aviation, had been chief scientist, Ministry of Defence (Army Department) since September, 1960. Dr. Cawood, who is 57, entered the Scientific Civil Service in 1938 and served for some eight years in the Headquarters Armament and Instrument Research and Development Branches of Air Ministry and Ministry of Aircraft Production. From 1947 to 1953 he was deputy director Royal Aircraft Establishment, Farnborough. The new chief scientist of the Army Department is **E. C. Cornford, B.A.**, who graduated in mathematics at Cambridge in 1938 and the same year joined the Ministry of Supply. For six years from 1945 he was in the guided weapons department of the Royal Aircraft Establishment. In 1951 he was appointed scientific adviser to the Air Ministry and three years later rejoined R.A.E. where he became head of the guided weapons department. Latterly, Mr. Cornford has been assistant chief scientific adviser (projects) in the Ministry of Defence.

**Dr. Gilbert F. Dutton**, head of recording research at EMI Research Laboratories, has been awarded the Emile Berliner Award of the Audio Engineering Society of America "in recognition of his pioneering work in the recording of sound and, in particular, the extended range of phonograph recording." Dr. Dutton joined the Gramophone Company, now part of EMI, in 1929. The Berliner award is made annually "for an outstanding development in the field of audio engineering."

An honorary doctorate of engineering has been conferred by the Brunswick Technical University on **Professor August Karolus**, the German television pioneer, who is 71 and now lives in Zürich, Switzerland. Dr. Karolus, who demonstrated an electro-mechanical television system using rotating mirrors in 1924, was consultant to Telefunken's television research department from 1924 until 1945. He was for some years professor of physics at Freiburg University.

Three managing directors of subsidiary companies in the G.E.C. Group have been appointed associate directors of the main G.E.C. Board. They are **J. Ayres, M.I.E.E., R. J. Clayton, O.B.E., M.A., F.Inst.P., M.I.E.E.**, and **T. C. Standeven**. Mr. Ayres joined G.E.C. in Coventry in 1921 as a general engineering apprentice. He joined the Brush Electrical Group in 1945 where he held a number of directorships until moving to the Sears Engineering Group in 1962. He returned to G.E.C. in November, 1963, as managing director of G.E.C. (Telecommunications) Ltd., Coventry. Mr. Clayton joined G.E.C.'s Research Laboratories in 1937, where he was engaged on research and development in various fields including guided weapons. He was appointed manager of the group of Applied Electronics Laboratories in 1958 and in 1961 became general manager of G.E.C. (Electronics) Ltd., and has been managing director since 1963. Mr. Clayton is a member of the Radio Research Board and of the Electronics Research Council of the Ministry of Aviation. Mr. Standeven, formerly general manager and managing director of Ultra Radio and Television Ltd., joined G.E.C. (Radio & Television) Ltd. in July, 1961, as managing director. In September of that year, he became director and general manager of Radio & Allied (Holdings) Ltd. and, in 1963 was appointed managing director.

**W. D. Day, B.Sc., A.M.I.E.E., A.M.I.E.R.E.**, who has been senior lecturer in the department of telecommunications and electronics at the Northern Polytechnic, London, for the past four years, has been appointed head of the electrical engineering department at Wimbledon Technical College. He joined the staff of the Northern Polytechnic in 1955 and has been responsible for studies in advanced engineering, radar, microwaves and pulse techniques. He himself studied at the college where he obtained his degree in special mathematics. From 1940 to 1946 Mr. Day was in the R.A.F. Technical Signals Branch and spent two years in Canada as signals officer (Flt. Lt.) at the Fighter Operational Training Unit. He was also

an instructor at several radio schools, including Cranwell. He is a council member of the Radar and Electronics Association. For eight years after the war he was radio instructor with B.O.A.C. Mr. Day is the author of "Introduction to Laplace transforms for radio and electronic engineers" published by Iliffe Books.

**D. H. W. Busby**, deputy manager of Mullard's Service Department for the past year, has been appointed manager in succession to **F. E. Debenham** who has retired after nearly thirty-six years with the company. Mr. Busby, who joined Mullard in 1950, spent several years in Mullard Applications Laboratory engaged on the development of audio-frequency equipment and has contributed to *Wireless World* on the design of audio equipment. He joined Beam-Echo Ltd. in 1958 but later returned to Mullard where he has been head of the Quality Liaison Department. He will continue to be responsible for this department.

**B. K. Blount, C.B., M.A., B.Sc., D.Phil.Nat.**, at present deputy secretary in the Department of Scientific and Industrial Research, is to be a deputy secretary in the Ministry of Technology when the D.S.I.R. is dissolved. Dr. Blount, who is 56, has been with the D.S.I.R. since 1952. During the war he served in the Army Intelligence Corps, later becoming director of the Research Branch of the Control Commission for Germany. Immediately before joining D.S.I.R., Dr. Blount was director of scientific intelligence at the Ministry of Defence.

## OBITUARY

**J. H. Owen Harries, M.I.E.R.E.**, who founded the company High Vacuum Valves (now Hivac) and has for the past seventeen years lived in Bermuda where he set up Harries Microphysics Ltd., died on January 9th at the age of 58. Mr. Harries' many contributions to the art of valve design included an all-stage valve which he described in this journal (20th November, 1936).

# NEWS FROM INDUSTRY

**Defence Consortium.**—An international electronics consortium which will compete for contracts for a new NATO air defence system (worth £110,000,000) was formed in Paris early in the New Year. The members of the consortium, which have pooled their knowledge in ultra-fast data handling techniques and a variety of new forms of radar designed to overcome jamming, are the Marconi Company, Hughes Aircraft Company, Compagnie Francaise Thomson-Houston, Selenia S.p.A., Hollandse Signaal-Apparaten, and Telefunken A.G. Contracts for this air defence system, known as NADGE (NATO Air Defence Ground Environment) are expected to be announced some time during the year. When completed, the system will provide a comprehensive integration of the NATO early warning chain, the Hawk/Nike missile network and the aircraft fighter squadrons in NATO.

**Satellite Contract.**—G.E.C. Electronics Ltd. have been appointed the main contractors for the electronic equipment for the UK 3 satellite by the Ministry of Aviation. This equipment includes a time multiplexed data handling system for the experiments and for the satellite performance parameters, a telemetry transmitter (136 Mc/s) and a telecommand receiver (148 Mc/s), and power control and regulation equipment. UK 3 is the third satellite in a joint Anglo-American venture and the vehicle will be the first to be built in Britain.

Standard Telephones and Cables Ltd. have formed an **electronic services division** at Harlow, Essex, to provide the industry with a fast supply service for the organization's ranges of components, circuit modules, sub-assemblies, racking, etc. As well as advising customers on the use of standard products from their own resources (including their parent, International Telephone and Telegraph Corporation, and its subsidiaries), the

new division will also carry complementary components and hardware manufactured outside their own organization and advise technically on matters relating to orders for special equipment.

**Emergency Equipment.**—A new version of the SOLAS transceiver for lifeboats and rafts, the Mk II, is to go into service with the Royal Navy. An order worth over £60,000 has been placed with the manufacturers, the International Marine Radio Company.

**International Computers and Tabulators Ltd.** have sold, in under three months, more than 100 of their new 1900 Series of computers, which have a combined value of over £13 M. Twenty-eight of the orders have come from overseas including five from New Zealand, four from South Africa and four from Australia. The first machine of the new Series was delivered to the Northampton College of Advanced Technology in January.

**Marconi Gear for North Sea Project.**—A radio telegraph system to provide communication between the many mobile drilling rigs in the North Sea and two shore stations on the East Coast is to be set up by the Post Office. Both of the shore stations ("Humber" in Lincolnshire and Stonehaven, near Aberdeen) are to be fitted with Marconi multi-channel telegraph transmitting and receiving systems (costing £150,000) and will provide up to 30 individual communication channels. Several of the drilling companies have ordered radio equipment housed in transportable shelters (similar to those sold in large quantities to the British Army) from the Marconi International Marine Company.

**A video tape-recording service** on a rental basis is now offered by Audio and Video Rentals Ltd., of Video House, 27-29 Whitfield Street, London, W.1.

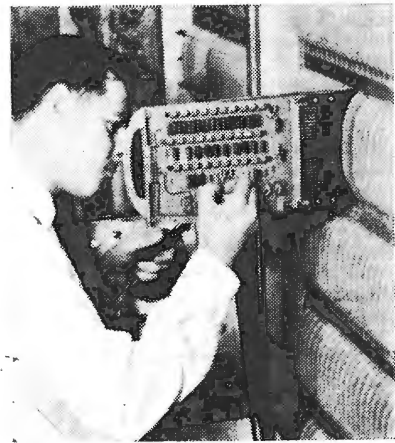

**English Electric-Leo-Marconi Computers Ltd.** have received an order from the British Post Office for five Leo 326 computers, valued at more than £2,500,000. This brings the number of Leo computers on order from the Post Office to seven and will make them the largest "commercial" user of computers in Europe. The illustration shows an engineer testing a logic circuit on the first Leo 326 for the Post Office.

**Japan Information Centre.**—The Japan Light Machinery Manufacturers' Association recently opened a London Information Centre with offices above the Japan Trade Centre at 535 Oxford Street, W.1. (Tel.: HYDe Park 3908.) The Centre has been set up to handle enquiries on many Japanese products including domestic radios and tape recorders.

**Pocket Size Transceivers.**—The radio communications division of G.E.C. Electronics Ltd. has received an order for 100 more "Lancon" pocket transceivers for the Lancashire County Constabulary. Already 100 of these have been supplied to the Lancashire police force.

**Stewart Aeronautical Supply Co.** have opened a branch office and stores at Hunting Gate, Wilbury Way, Hitchin, Herts. This is the first of a series of about eight branches to be set up throughout the country during the next two years.

**Gresham Lion Electronics Ltd.**, of Twickenham Road, Hanworth, Middx., have formed a separate magnetic recording head department. The company began manufacturing magnetic recording heads eight years ago.

The International Nickel Company (Mond) Ltd. is in future to be known as **International Nickel Ltd.** The new name further emphasizes the identification with the parent company, the International Nickel Company of Canada.

The London computer training centre of English Electric-Leo-Marconi Com-

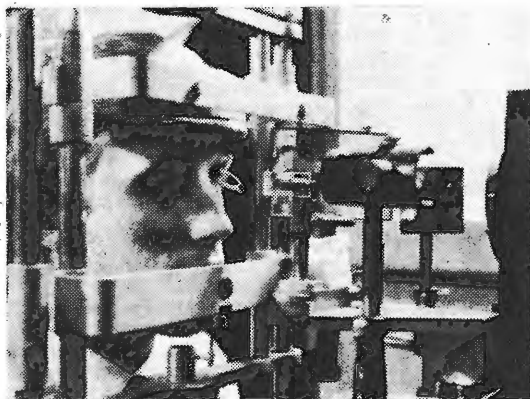

**The human eye makes a number of involuntary movements when the gaze is fixed on a stationary point.** This is being studied by Reading University and a transistorized data processing system has been specially developed by the M.E.L. Equipment Co. for the project. The subject wears a contact lens to which is attached a small mirror, and his head is held steady in a frame.

puters Ltd. has moved from Hartree House, Queensway, W.2, to Radley House, 35-39 South Ealing Road, W.5. The first course at the new centre began on 4th January.

**Hewlett-Packard Ltd.**, the U.K. subsidiary of the American organization, is soon to start building a new plant and laboratories at South Queensferry, near Edinburgh. The first phase, covering 80,000 sq ft, will cost nearly £500,000 and extensions during the next ten years are hoped to more than triple the size of the plant.

**Electronic Instruments Ltd.** of Richmond, Surrey, have set up a separate office at 209 Crescent Road, New Barnet, Herts. (Tel.: Hadley Green 3083) to deal with the sales and service in Southern England formerly handled by their Richmond office.

**Thorn-AEI Radio Valves & Tubes Ltd.** have closed their Mazda and Brimar picture tube service depot at 853 Bath Road, Brislington, Bristol. West of England dealers should now send any tubes for which replacement is claimed under guarantee to the London depot at Brimsdown, Enfield, Middx. (Tel.: Howard 1201.) Other Mazda and Brimar provincial service depots will be retained, since they are located at premises also used as distribution centres.

## From overseas

### Germany

The Decca Navigator Company Ltd. have received an order, valued at over £500,000, for the supply of a number of Decca Navigators and true motion radars from DIA Elektrotechnik, Berlin. This brings the total orders for Decca equipment supplied to East Germany since 1962 to well over £1,000,000.

Rohde and Schwarz have received an order from the German meteorological service for a v.h.f. weather station for receiving pictures transmitted from weather satellites. The station, which is to be the first in national use, is to be set up in Offenbach and will feature a punched-tape controlled aerial.

### Holland

Tequipment Ltd. have received an order from the European Space Research Organization for 12 of their double-beam portable oscilloscopes and 30 plug-in amplifiers for use at the European Space Technology Centre (ESTEC) at Delft, Holland. The equipment will be used for laboratory work at the centre.

### India

A number of Eureka transponder beacons, to the value of £56,000, have been supplied to the Indian Government under the British Aid to India programme, by Rank Bush Murphy Electronics.

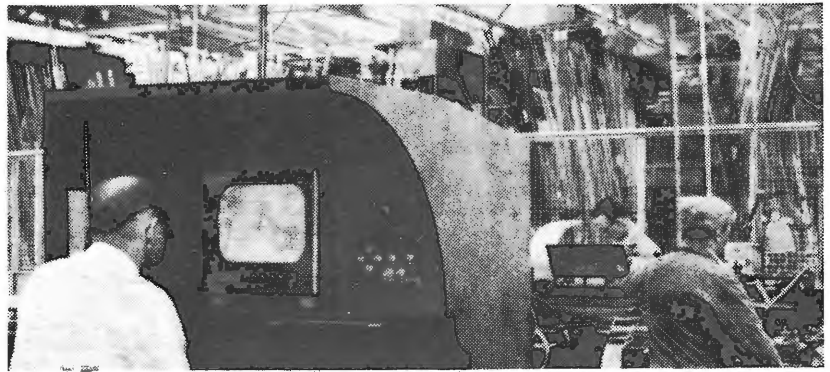

**A Marconi closed-circuit television system installed at the company's Basildon plant in Essex has resulted in the saving of over 2,000 man-hours a year through providing visual reference to production drawings on the shop floor. Five television monitors, like the one illustrated, are placed at strategic points on the shop floor and fed from an industrial television camera and control unit based in the print store. This base station also includes a monitor and a central control desk which incorporates a two-way communications unit linking each of the outstations.**

### Nigeria

The General Electric Company have won a contract, valued at £1,750,000, from the Government of Nigeria for s.h.f. telecommunications equipment for the first phase of the Nigeria telecommunications system development programme providing links between Lagos, Ibadan, Enugu and Port Harcourt.

### Sweden

A substantial order for high-power silicon diodes has been placed with the International Rectifier Company (Great Britain) Ltd. by ESAB of Sweden. This order calls for 20,000 diodes and brings the total number of this particular diode (70U) purchased by ESAB in the past two years to 50,000.

The Painton Group of Companies have now acquired the remaining shares in Svenska Painton AB Stockholm, which now becomes a wholly owned subsidiary.

### Syria

The Directorate of Broadcasting and Television of the Syrian Arab Republic has awarded a contract for the supply of two 5 kW, 625-line television transmitters to Pye T.V.T. Ltd. The transmitters are to be installed on the summit of Mount Nabi Matta, which is near Slenfeh in North Syria.

### U.S.A.

EMI-Cossor Electronics Ltd., of Canada, have been awarded a contract by the United States Navy, worth approximately \$1 M, for the development of a special ionospheric oblique sounder. It will be used to ascertain the best operational frequency for long-range h.f. communication.

Beckman Instruments Incorporated, of California, are to develop a physiological instrumentation system for the Gemini two-man orbital space-craft under three contracts, valued at over \$150,000, from the National Aeronautics

and Space Administration. The system will be used to help safeguard the well-being of the astronauts in flight and will include a unit to artificially stimulate blood circulation in the legs during the prolonged periods of weightlessness and inactivity, and devices to monitor the heart and brain.

### U.S.S.R.

The first Soviet order for VOR navigational beacons has been placed with Standard Telephones and Cables Ltd. by Aviaexport of Moscow and calls for two high-power, long-range beacons to be installed between Moscow and the Baltic coast.

## Agencies and Agreements

**Siemens—R.C.A. Data Processing Agreement.**—The Radio Corporation of America and Siemens & Halske have strengthened and widened their reciprocal agreements for the interchange of information in the data processing field. This covers development, manufacture and sales.

The Kyoto Ceramic Company, of Kyoto, Japan, have appointed Takbro Industrial Ltd., of Lloyds Bank Chambers, 85 Regent Street, Leamington Spa, Warwickshire, to act as their sole U.K. agents.

Jenkins Fidgeon Ltd. have been appointed sole U.K. agents for "Computape", a magnetic recording tape suitable for a wide range of computer applications, made by Computron Incorporated, of Massachusetts.

Tacussel Electronique, of Lyons, France, who manufacture a range of electronic instruments for use in the electro-chemical field, have appointed d-mac limited, of 55 Kelvin Avenue, Glasgow, S.W.2, to act as their U.K. distributors.

# Further Notes on SIGNAL FLOW DIAGRAMS

RULES FOR WRITING AND REDUCTION

By W. GRANT, B.Sc.

THE use of signal flow diagrams has perhaps been discouraged by the seeming difficulty of their manipulation. Mr. Truxal<sup>1</sup> brought them from the realm of pure mathematics into that of technology (at least as far as I am concerned). Mr. Roddam<sup>2</sup> very considerably simplified the task of constructing the initial diagram and likened the diagram to a map—but the map is topological, not geographical. The signal flow diagram bears a likeness to the London Underground route plan, from which no stranger can guess that it is quicker to walk to Trafalgar Square (two stations away, with an interchange) from the entrance to Strand station than to the Strand station platform.

The Underground route plan is not concerned with geography; its layout is designed to present clearly the order of the stations and the interchanges between different sections of the system. The signal flow diagram presents the order in which the signal meets the "ports" (that is, the points in the circuit which bear relations to one another specified by a complete set of equations fully describing the circuit) in its progress from input to output.

This analogy begins and ends when the signal flow diagram is used to display the effect of circuit elements in forming the dynamic characteristic of a given circuit. Such use of the diagram is illuminating but elementary. The diagram becomes a very powerful tool when the effects of circuit modifications are to be estimated. In its concentrated form the diagram sets out the effect which each circuit element, or group of elements, has on the signal quite precisely. As a result the possibility of design by intent rather than by rule of thumb is brought much closer. In other words, belt, braces, and a bit of string may all be necessary; but it is more likely that a good belt alone will prove fully adequate, and certainly less troublesome.

Mr. Roddam, in a later letter<sup>3</sup>, stated that his own preference was for another method, for which he claimed the advantage that it was like knitting and could be laid down and picked up at will without loss of time. This started a challenging train of thought: how many hours of every engineer's time were wasted in picking up the threads of interrupted problems? What signposts were necessary? What should they be? In answering the last two questions it soon became clear that they had relevance only to the framework, since the signal flow diagram is a simple aspect of the discipline of topology, and is subject to the logic of that discipline. The arithmetic of the diagram is easier than that of the complex algebra for which it provides a scaffolding and may profitably be studied independently of the parameters

of the circuitry which is the subject of the analysis and synthesis.

As an outcome of these thoughts the scheme set out below was evolved. Items 3 and 4 are discussed in the notes which follow. Item 3 is considered in some detail, and some elementary theorems of topology are presented.

1. Construct the initial diagram from the equations which apply to the interconnection of elements of the circuit. The shape of this diagram is not particularly important, but more, rather than less, space helps to avoid confusion and error. If all ports are drawn  $\bigcirc$ , then it is clear that any lines which cross away from ports are unconnected.

2. Eliminate all through ports; each transmission path now runs from an input or junction port to a junction or output port, and the value of each is the product of the values of the initial parameters along the "string." Label each of the transmission paths with a lower-case letter to simplify the manipulation of the diagram. N.B. However odd it may appear,  $-10 \text{ ohms} - 0 - 25 \text{ ohms}$  becomes  $250 \text{ (ohms)}^2$ .

3. Concentrate (a more apt word than simplify or reduce) the diagram.

4. Examine the concentration and sort the transmission symbols under the headings:—

- (i) forward transmission only
- (ii) forward and loop transmission
- (iii) loop transmission only.

5. Rewrite the concentration in terms of the actual transmission parameters, and manipulate these within the rules of the algebra of the complex variable, taking account of the observations of 4.

## ELEMENTARY THEOREMS

### Axioms

- 1a.1  $\text{---}\bigcirc\text{---}$  Main port, or minor port when emphasis required.
- 1a.2  $x > \bigcirc$  Input port accepting a signal of value  $x$ . There is usually only one input port and the input is assumed to be of unit value.
- 1a.3  $\bigcirc >$  Output port.
- 1a.4  $\bigcirc_t$  Test port, when required and neither input nor output. In practice (though it has nothing to do with this study) it is desirable to state the connected load which is permissible if the output is not to change by more than (say)  $1 \text{ dB} / 5^\circ$ .
- 1b.  $\text{---}\rightarrow\text{---}$  Transmission path from port to port. Signal flow is valid only in the direction of the arrow; it is meaningless against the arrow.

1. "Automatic Feedback Control System Synthesis," by J. G. Truxal. McGraw-Hill Book Co. Inc., New York, 1955.

2. "Signal-Flow Diagrams," by Thomas Roddam. *Wireless World* February and March, 1960.

3. *Loc. cit.* Nov. 1960, p. 562.

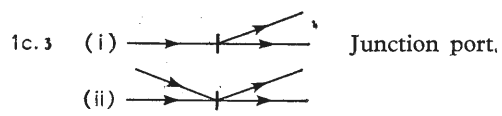
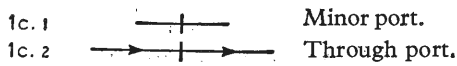

1d.  $\Delta_{xyz}$  This symbol may be added to any port, or the detached label of any port when the port has been eliminated, when the loop has been transferred to the transmission arithmetic, if the information may be usefully preserved.

1e.  $\phi^{gh}$  This symbol indicates a port not subject to the stated (and any later) feedback, if the information may be usefully preserved.

**Theorems (a. elementary; b. and/or derived)**

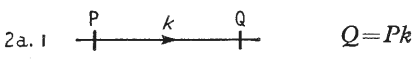

The signal arriving at a port is the product of the signal at the immediately previous port and the transmission parameter.

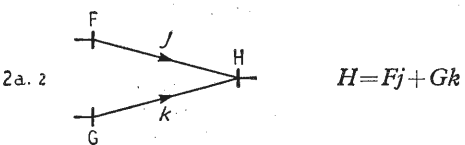

The signal at a port is the sum of all signals arriving at the port—except in the case of a looped port, for which see theorem 2.c.

It is not obvious at first sight that the likeness of signal flow diagrams to circuit diagrams is misleading. Ports are not circuit joints; each is a position where the arriving signals interact to generate the signal to be transmitted. The interaction is described by the arithmetic. Theorems of this logic are progressive; later theorems do not contradict earlier ones, but limit their application. Two cardinal principles apply: if in doubt, move step by step; if still in doubt use the arithmetic.

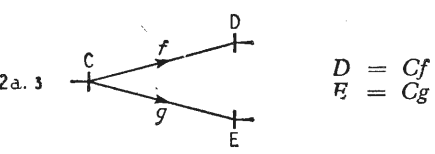

The signal at a port is transmitted along all paths leaving the port.

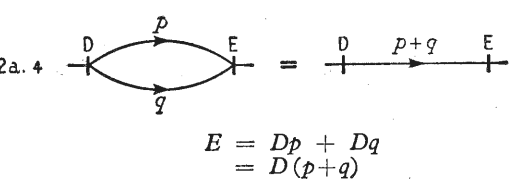

Paths in parallel are added.

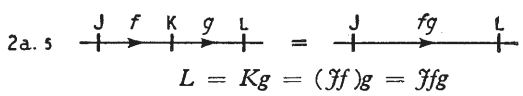

Paths in series are multiplied.

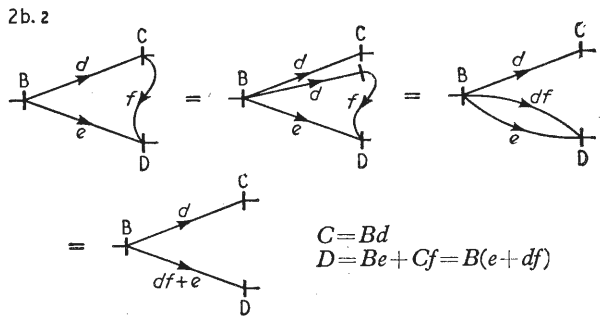
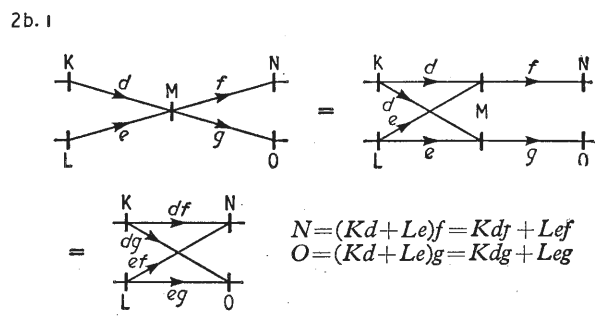

The above two theorems introduce the idea of splitting a junction, and this develops into the procedure of "peeling" a loop.

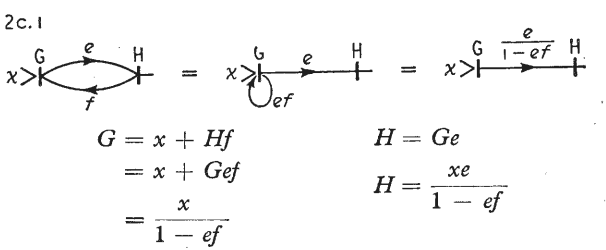

This theorem cannot be derived from the previous diagrams. See the note to 2a.2. Port G is not schizophrenic; the signal x is not referred to the same zero as the signal G. In a cathode follower, for instance, the input signal x is the p.d. between grid and negative rail, while the signal G is the p.d. between grid and cathode. Applying the procedure of extension:—

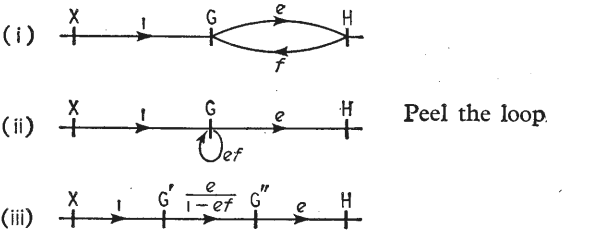

This diagram regards the loop as a modifying influence on the signal within port G—detail correct.



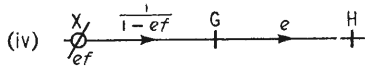

This diagram regards the loop as a modifying influence on the signal received by port G—result correct.

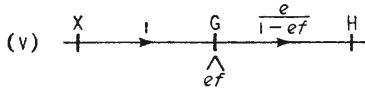

This diagram regards the loop as a modifying influence on the forward path e—result correct.

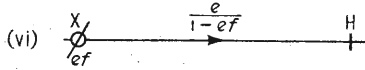

The diagrams (iii), (iv), (v), and (vi) all represent the correct result at port H. Diagram (ii) is as far as concentration need go, since (vi) follows in final translation. The “knitting” symbols  $\phi_{ef}$  and  $\wedge_{ef}$  are useful when the procedure is interrupted.

Another concept is introduced in this theorem which is valid throughout the logic: No path may pass through the same port twice. It is correct to eliminate port H from the path  $GeHfG$ —and G is a terminal for that path.

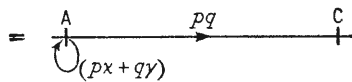
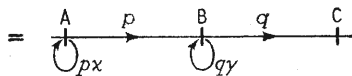
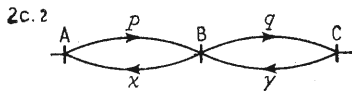

$$\begin{aligned}
 C &= Bq \\
 B &= Ap + Cy \\
 &= Ap + Bqy \\
 &= \frac{Ap}{1 - qy} \\
 A &= 1 + Bx \\
 &= 1 + \frac{Ap}{1 - qy} \\
 &= \frac{1 - px}{1 - qy} \\
 C &= \frac{pq}{1 - (px + qy)}
 \end{aligned}$$

Contiguous loops are coalesced and summed (within the bracket).

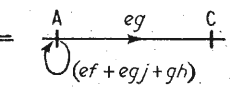
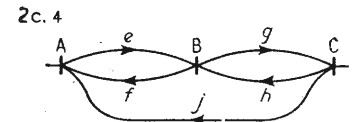
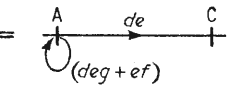
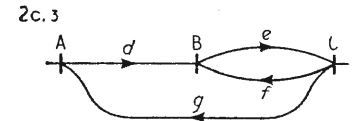

The procedure of summing contiguous loops is not limited to two loops; it may be continued to as many loops as are truly contiguous.

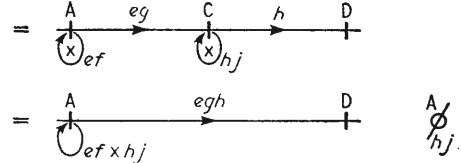
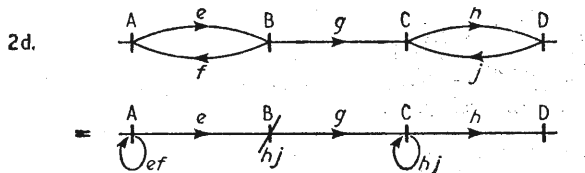

$$\begin{aligned}
 A &= 1 + Bf \\
 B &= Ae \\
 \text{So } A &= 1 + Aef \\
 &= \frac{1}{1 - ef} \\
 \text{and } B &= \frac{e}{1 - ef} \\
 D &= Ch \\
 C &= Bg + Dj \\
 &= \frac{Bg}{1 - hj}
 \end{aligned}$$

Substituting for B

$$C = \frac{eg}{(1 - ef)(1 - hj)}$$

$$\text{whence } D = \frac{egh}{(1 - ef)(1 - hj)}$$

Non-contiguous loops are not coalesced and summed. Each loop generates its own feedback term and the total feedback is the product of these terms.

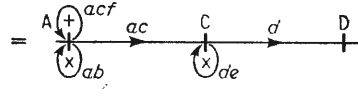
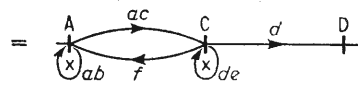
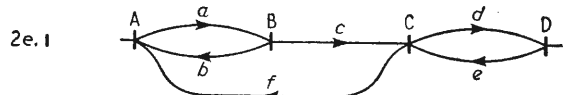

$$\begin{aligned}
 A &= 1 + Bb + Cf \\
 B &= Aa \\
 C &= Bc + De \\
 D &= Cd \\
 \text{So } C &= Bc + Cde \\
 &= \frac{Bc}{1 - de}
 \end{aligned}$$

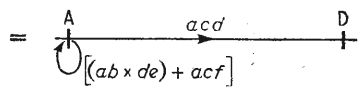

$$\text{Substituting for B}$$

$$C = \frac{Aac}{1 - de}$$

$$\begin{aligned}
 \therefore A &= 1 + Aab + \frac{Aacf}{1 - de} \\
 &= 1 + A \frac{ab - abde + acf}{1 - de} \\
 &= 1 - \frac{(ab - abde + de + acf)}{1 - de} \\
 \text{whence } D &= \frac{acd}{1 - (ab - abde + de + acf)}
 \end{aligned}$$

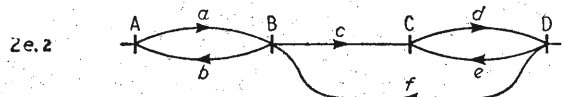

$$D = \frac{acd}{1 - (ab - abde + de + cdf)}$$

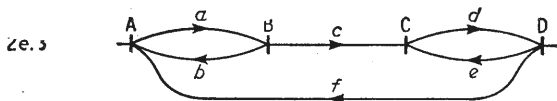

$$D = \frac{acd}{1 - (ab - abde + de + acdf)}$$

The loops *ab* and *de* generate multiplying terms and the "embracing" loop generates a term to be added. It is not profitable to deduce this theorem from previous ones; it is to be learned and accepted as it is.

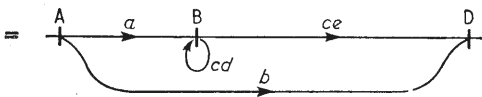
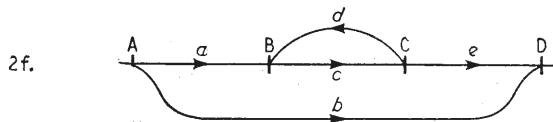

and  $D = \frac{ace}{1 - cd} + b$ . This does not look, and is not, very profound. It is to be contrasted with 2g.

2g.1

$A = 1$   
 $B = a + Cd$   
 $C = b + Bc$   
 So  $B = a + bd + Bcd$   
 $= \frac{a + bd}{1 - cd}$   
 $\therefore C = b + \frac{(a + bd)c}{1 - cd}$   
 $= \frac{b - bcd + ac + bcd}{1 - cd}$   
 $= \frac{ac + b}{1 - cd}$

Note the correct and complete transmission path from *A* to *B*. Theorem 2g.1 is a particular case of 2f where the total transmission from the looped port to the port where the parallel branch meets is included in the loop.

It pays to peel all loops at the earliest port, in the first instance. Otherwise 2f looks like 2g before the loop identity is checked.

2g.2

$$D = \frac{ac + be}{1 - (cd + ef)}$$

This appears obvious, yet the arithmetic is tedious and requires some care.

When the shape of a theorem is recognizable in the course of an analysis the result is reached faster than if the arithmetic must be drudged through. The shape must be exact. It is possible to develop further theorems, and no doubt those who need them often will do so, or have done so already. Those above are a reasonable balance between time saved by safely skipping arithmetic and time lost by memory's errors.

### EXAMPLES

Many of the problems which arise in practice are illustrated by considering the following diagram structure.

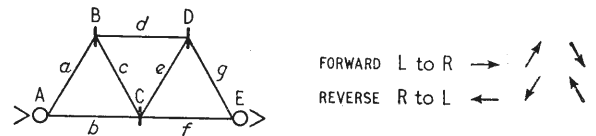

The total number of possibilities—flow in either direction in each path—is 128, of which 37 comply with the requirement that port *A* is the only input and port *E* the only output. Three of the 37 have no feedback loop, and of the 34 remaining a few are discussed. Discussion of all 34 would take up more space than is justifiable here; but it is a rewarding exercise towards fluency in the use of signal flow diagrams.

#### 3a. REVERSE *c*

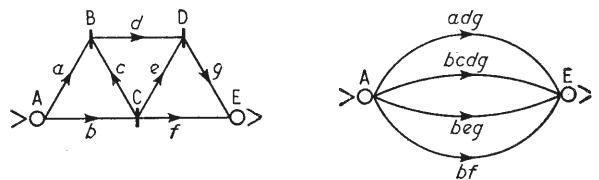

#### 3b. REVERSE *d* -- 2g.1

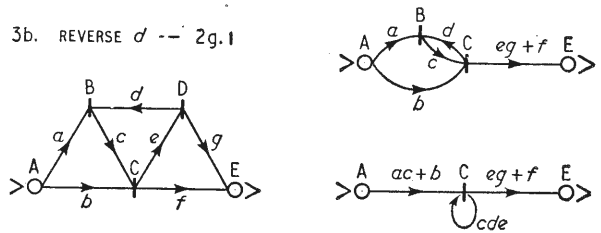

#### 3c.1 REVERSE *a* & *d* -- 2c.2

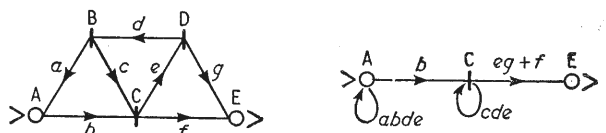

$$A = 1 + Ba$$

$$B = Dd = Cde = \frac{Abde}{1 - cde}$$

$$D = Ce$$

$$C = Ab + Bc = Ab + Ccde = \frac{Ab}{1 - cde}$$

$$A = 1 + \frac{Aabde}{1 - cde} = \frac{1 - cde}{1 - (abde + cde)}$$

$$C = \frac{b}{1 - (abde + cde)}$$

$$E = Cf + Dg = C(eg + f)$$

$$= \frac{b(eg + f)}{1 - (ab + c)de}$$

3c.2 REVERSE  $b$  &  $f$  — 2c.2, 2g.1

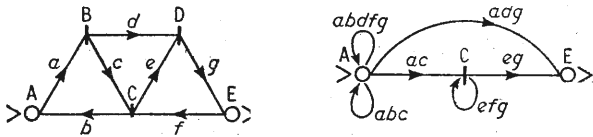

$$A = 1 + Cb; B = Aa; C = Bc + Ef;$$

$$D = Bd + Ce; E = Dg;$$

$$\text{So } C = Bc + Bdfg + Cefg$$

$$= \frac{B(c + dfg)}{1 - efg}$$

$$= \frac{Aa(c + dfg)}{1 - efg}$$

$$= \frac{a(c + dfg)}{1 - ab(c + dfg) + efg}$$

$$\text{and } A = 1 + \frac{Aab(c + dfg)}{1 - efg}$$

$$= \frac{1 - efg}{1 - efg - ab(c + dfg)}$$

$$E = Bdg + Ceg = \frac{adg(1 - efg)}{D} + \frac{aeg(c + dfg)}{D}$$

$$= \frac{adg - adefg^2 + aceg + adefg^2}{D}$$

$$= \frac{ag(ce + d)}{1 - ab(c + dfg) + efg}$$

3c.3 REVERSE  $c$  &  $e$

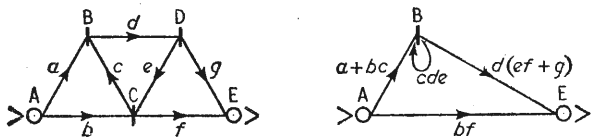

$$\text{Whence } E = bf + \frac{(a + bc)d(ef + g)}{1 - cde} \dots\dots\dots (i)$$

$$= \frac{bf - bcdef + adef + bcdef + adg + bcdg}{1 - cde}$$

$$= \frac{ad(ef + g) + b(cdg + f)}{1 - cde} \dots\dots\dots (ii)$$

This result suggests another diagram:—

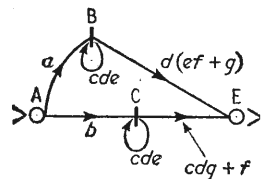

which may be reached directly by sketching the path  $AaB \dots$  in parallel with the path  $AbC \dots$

3d.1 REVERSE  $a, c$  &  $e$

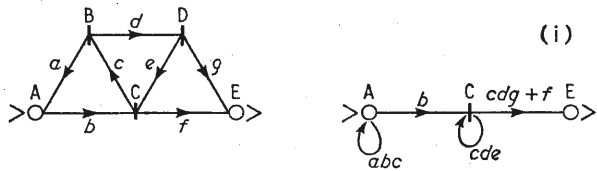

It is tempting, but invalid to sketch:—

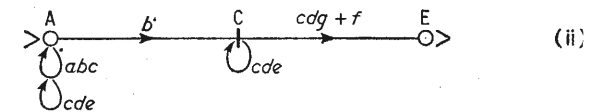

The correct statement, within the present range of theorems, for the case of the "littler flea" is:—

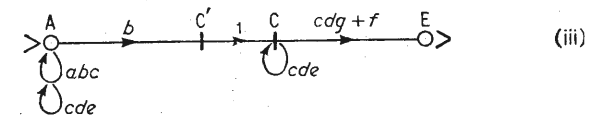

$$(iii) = \frac{b}{1 - \frac{abc}{1 - cde}} \times \frac{cdg + f}{1 - cde}$$

$$= \frac{b(1 - cde)(cdg + f)}{1 - (abc + cde)(1 - cde)} = \frac{b(cdg + f)}{1 - (abc + cde)}$$

The added unit transmission path is to avoid contiguous loops. Moral: When a loop appears on a loop, beware.

3d.2 REVERSE  $a, d$  &  $g$

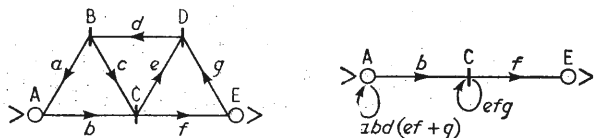

3e.1 REVERSE  $a, c, d$  &  $f$

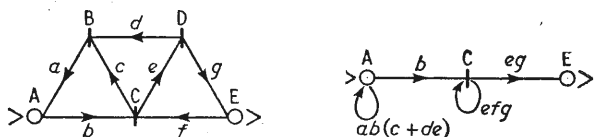

3e.2 Reverse  $b, d, e$ , and  $g$

From symmetry the answer may be written by comparison with 3e.1. It is useful to do so; sketch the intermediate figure from the answer, and check that it agrees with the data. This exercise is not pointless. It describes one process of synthesis.

3f. REVERSE  $a, c, d, e$  &  $g$

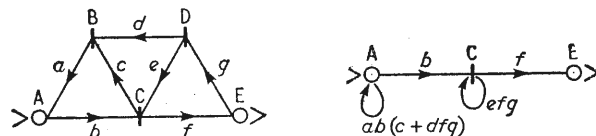

This result may be derived from that of 3c.2 by the principle of symmetry.

$$ab(c + dfg + efg) = abc + (abd + e)fg$$

3.g. A procedure which is helpful on occasion is to set out the most direct forward transmission in a straight line. For example, reverse  $a, c, e$ , and  $f$ .

3g. REVERSE *a, c, e & f*

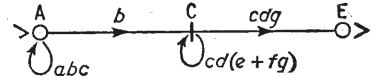
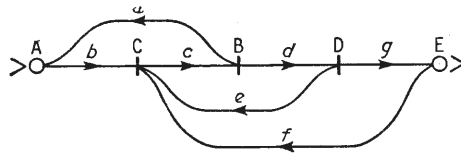
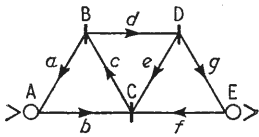

**The Sort**

- (i) forward transmission only
- (ii) forward and loop transmission
- (iii) loop transmission only

Reference	Output value	(i)	(ii)	(iii)
3.b.1	$\frac{(ac+b)(eg+f)}{1-cde}$	abfg	ce	d
3.c.1	$\frac{b(ef+g)}{1-(ab+c)de}$	fg	be	acd
3.c.3	$\frac{ad(ef+g)+b(cdg+f)}{1-cde}$	abfg	cde	—
3.d.2	$\frac{bf}{1-(ab+c)d(e+fg)}$	—	bf	acdeg

Gain and output phase may be modified by altering one or more of the terms in column (i), and stability is not affected. When stability is in question, each of the looped paths must be investigated, and the intermediate diagrams set these out. The effect of the terms in columns (ii) and (iii) on gain and phase can be determined by differentiation, but alterations are limited by the stability requirements.

Investigation by signal flow diagram is no substitute for assessment of the correct equivalent circuit for each component (in the frequency range of the problem), nor for an understanding of the algebra of the complex variable, but it directs attention to the most profitable terms. Examination of the diagram as a topological entity, setting aside for a time the true circuit parameters, saves writing time and labour; and, by reducing the number of symbols in view, lessens the risk of transposition errors from line to line.

## MICROWAVE CIRCUIT DESIGN

ONE of the more striking developments in microwave engineering in the years since the second world war has been the impact of network theory on what was once jocularly described as "plumbing." The reason for this interesting application of lumped-element circuit theory to distributed-element structures has been the great expansion of microwave techniques that has taken place since the war. No longer are we concerned merely with the transmission of microwave signals, but with their manipulation in an increasing variety of waveguide and coaxial systems and components. This growing complexity has encouraged a more analytical approach in design, and a particular feature of this has been the adaptation of existing lumped-element network theory to microwave requirements.

An introduction to these design methods was presented by the I.E.E. last December in the shape of a one-day colloquium on "Modern techniques for microwave circuit synthesis." Arranged by the professional group on microwave techniques of the Electronics Division, the event was intended to be tutorial in character, and included a mixture of introductory theory and practical design papers. A commonly used design procedure mentioned by several contributors was first to synthesize on paper a lumped-element network that would provide the required performance and then transform the RLC values obtained into equivalent waveguide or coaxial-line elements—capacitors into open-circuited stubs, inductors into short-circuited stubs and so on. In some situations, however, this method could lead to stubs of unsuitable dimensions and characteristics, and better results could be obtained by a more direct approach using a technique (due to P. I. Richards) for transforming impedances as functions of the complex frequency variable *s* into functions of a new complex frequency variable *t*.

The relationship between *s* and *t* was  $t = \tanh(ls/c)$ , *l* being the length of the basic transmission line element to be used throughout the network and *c* the velocity of e.m. waves in the medium concerned. Starting with the specified frequency characteristic of the circuit, the designer found an impedance function of *t* which approximated to this curve and then derived from this function the required lengths of

open- and short-circuited stubs to be assembled to form the circuit.

One example of the application of this method was to the design of a three-element 2-8 Gc/s band-pass filter for insertion in a coaxial transmission line. The purpose of the filter was to provide a d.c. return in the line (connection between inner and outer conductors) for a diode, and the technique adopted was to use a band-pass filter configuration with shunt inductive elements at its input and output. The d.c. connection was provided by the short-circuited shunt stubs representing these inductances.

Other examples of microwave circuit synthesis using established network theory were the design of "multilayer" distributed-element filters for waveguide (constructed from successive layers of dielectric material within the waveguide) and the design of tunnel-diode (negative-resistance) amplifiers for microwave frequencies. In the last-mentioned technique the signal was applied to the negative-resistance diode and reflected at increased amplitude, a circulator being used to separate the incident and reflected waves. The design problem was to synthesize a lossless network for insertion between the circulator and the tunnel diode (considered as a parallel combination of  $-R$  and  $C$ ) that would allow a required gain and bandwidth to be obtained.

"Logic Without Tears." In the article by H. R. Henly in the previous issue we regret that the following errors occurred.

- (1) The figure numbers to Figs. 21 and 22 should be interchanged.
- (2) Page 49, col. 1, line 10. The four gates referred to should have been shown erased in Fig. 22, now Fig. 21. They are: the right-hand gate in the box labelled GATE 1; the right-hand gate in the box labelled GATE 2 and the two left-hand gates in the box labelled GATE 3.
- (3) Page 48, col. 2, line 18 should read:—

$$F = A.B.C = A+B+C = A+B+C$$

# Wide-range Transistor Wobbulator

USING THE PRINCIPLE OF CURRENT DIVISION AND MUTUAL INDUCTANCE

By K. C. JOHNSON, M.A.

**A** WOBBLATOR is an oscillator whose frequency can be controlled from an input voltage by purely electronic means. Such a circuit is used for generating sweep waveforms for the alignment of the tuned circuits in radio receivers, for example, and the same principle is required for the generation of frequency-modulated transmissions and for automatic frequency control systems. The essential feature of the arrangement is that there is an effective reactance connected to the controlling tuned circuit of the oscillator of which the value can be varied in response to an input voltage without any sort of mechanical movement. Thus input signals containing high-frequency components can be applied and the output frequency will follow them faithfully.

One straightforward way of achieving this is to shunt the tuning capacitor of any ordinary type of oscillator with a reverse biased semiconductor junction diode. The effective capacitance of such a diode decreases as the back-voltage is increased, due to the widening of the depletion layer, and suitable diodes are now available with large ratios of capacitance variation, low series resistance and even specially tailored voltage/capacitance characteristics. Circuits based on this principle, however, have the drawback that the oscillatory voltage swing across the diode must be small in comparison with the range of the controlling voltage, so that the power output of a simple oscillator is limited, and the frequency variation obtainable is usually only a small percentage of the central value.

A second method, which uses only conventional components, relies on the fact that it is comparatively easy to construct an amplifier whose gain can be varied by the alteration of biases applied to the active elements. If a capacitor is connected from the output of a voltage amplifier back to the input terminal then, as in the familiar Miller effect, a large effective capacitance will appear at the input if, for example, the overall gain of the amplifier is negative and large. If the overall gain is made to change, then this effective capacitance will also change and it is fairly easy to make an oscillator whose frequency alters accordingly. The well-known "reactance valve" form of wobbulator is a good example of this type and the principle has been widely used.

Surprisingly little use seems, however, to have been made of the possibility, which was discussed by the author in *Wireless World* as long ago as April and May 1949, of using a variable-gain amplifier with inductive feedback from the output to the input. It is true that the amplifier must be a current amplifier, but the principle is essentially similar and the effective inductance varies with the gain in the same manner. The great advantage of the inductive arrangement is that the phenomenon of mutual action allows much more flexibility in the design, since the input and output of the

amplifier can be separated in a way which is quite impossible with capacitors and, furthermore, a turns ratio is available to give a further degree of freedom. These advantages are illustrated by the practical wobbulator circuit shown in the diagram.

The transistors Tr1 and Tr2 together form a common-base amplifier and take as their input oscillatory current from the tuned circuit formed by  $L_1$  and  $C_1$ . Their combined output currents develop an amplified voltage across  $R_5$  which is, in turn, coupled through  $C_2$  to the base of Tr3. This third transistor then gives

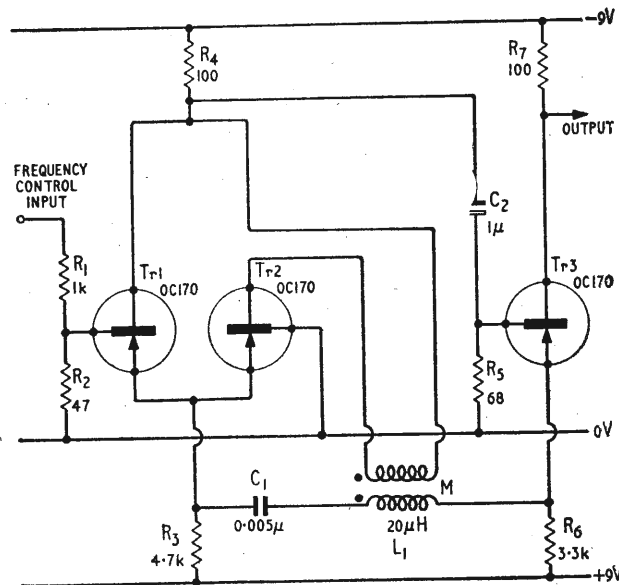

Experimental circuit covering a frequency range of 0.48 to 1.13 Mc/s.

current gain by emitter-follower action and returns the amplified signal to the tuned circuit so that steady oscillations are maintained. At the same time the oscillatory current is available at the collector of Tr3 and can be used to give an output, buffered by the high collector impedance, by inserting a load resistor such as  $R_7$ . Now the amplitude of the oscillations in a circuit of this type is limited by cutting-off at the emitters of Tr1 and Tr2, so that the peak current in the oscillatory sine-wave, and hence also in  $R_5$ , will be closely equal to the standing d.c. in  $R_5$ . If this condition is not maintained within a few per cent throughout the full range of frequency variation then the value of  $R_5$  should be adjusted appropriately to raise or lower the loop gain.

So far only the combined action of Tr1 and Tr2 has

been considered and the fact that the current has been divided between two transistors has not in fact affected the argument at all, but let us now consider this action more carefully. The resistors  $R_1$  and  $R_2$  serve to attenuate the input voltage by a factor of about twenty, so that an input of  $\pm 1V$ , makes a change of  $\pm 0.05V$  at the base of Tr1, and at the same time  $R_2$  reduces the impedance so that Tr1 sees almost an ideal voltage source. Now it is well known that the mutual conductance characteristic of any ordinary transistor is almost perfectly exponential and this means that for any fixed voltage between the bases of Tr1 and Tr2 there will be a fixed ratio in which any current coming to the emitters is divided between them. It can be shown, that a voltage difference of near  $0.05V$  is required to give a division ratio of 10:1 for any type of transistor made of any normal semiconductor and kept near to room temperature. Hence a signal at the input terminal of not much more than  $\pm 1V$  will serve to switch the current almost completely across between one transistor and the other.

Thus the transistor Tr2 serves as the current amplifier of variable gain that was required, and it is no handicap that the maximum value of the gain obtainable is barely unity. The collector current of this transistor is made to flow in a winding which has mutual coupling with the main tuning inductor  $L_1$  and this gives the expected variation of the oscillatory frequency. The details are not at all critical, but the actual inductor used was wound on a  $\frac{3}{8}$ in diameter former and had 50 turns of  $21 \times 46$  s.w.g. Litz wire in a single layer about 2in long for the main winding and 45 turns of the same wire wound directly over it for the mutual. These were connected as shown in the circuit so that the current in the mutual opposes that in the main winding and reduces the effective tuning inductance. With the components and values shown, the variation actually obtained was from 0.48 Mc/s to 1.13 Mc/s and so would cover almost the whole medium wave band.

If a wider coverage than this is attempted, by increasing the number of mutual turns, then the oscillation may jump to a different mode at a higher frequency. This seems to be a function of the cut-off frequency of Tr2 and it is for this reason that alloy-diffused transistors have been used. If OC44s are substituted in the identical circuit then the highest frequency attainable is reduced to 0.9 Mc/s. Some improvement may perhaps be obtained here by the use of a ferrite core to decrease the leakage inductance between the windings, but this has not been investigated as yet.

For some purposes the construction of a potentially wide range wobulator like this may be justified only by the accurate linearity and constant amplitude that it can give over a narrow range of actual operation. If this is the case it may be found that the central frequency of this circuit drifts due to differential temperature changes in Tr1 and Tr2. This effect can be stabilized by splitting the resistor  $R_n$  into separate components for the two transistors, so as to define separate average currents, and then using a capacitor of perhaps  $1,000 \mu F$  to connect the two emitters. A large capacitor is needed to avoid distortion of any low frequencies and the polarizing voltage for an electrolytic can easily be introduced by adding a small d.c. component to the base drive of Tr1.

The wide range of variation obtainable from this circuit suggests that it might perhaps be developed to make a voltage-tuned radio receiver operating over the whole medium band. In any case it is clearly possible to make a tunable selective amplifier by, for example,

adding a high-frequency input to the bases of both Tr1 and Tr2, shorting the "dead" end of  $L_1$  to ground, and taking an output from  $R_n$ . Lastly there is the amusing possibility that this type of variable reactance might, like the back-biased semiconductor diode, be made to yield a low-noise amplifier by means of "parametric" action.

## Commercial Literature

The 1965 edition of the **Mullard Industrial Valve Guide** is now available from the industrial markets division of Mullard Ltd., whose headquarters are at Mullard House, Torrington Place, London, W.C.1. Like the previous edition, the new guide has been produced in two sections, in fact two separate booklets. Some 100 pages are included in the "equivalents guide" which contains an index of all Mullard valves and tubes for industry, communications and radar, plus a comprehensive guide to the various valves and tubes for which Mullard types may be used as replacements. The "abridged data on current types" runs to some 40 larger pages and contains sections covering receiving valves, electron optical devices, photosensitive devices, vacuum devices, cold cathode devices, power devices, transmitting valves and microwave devices.

2WW 323 for further details

**Small Signal Characteristics of STC Silicon Planar Transistors** is the title of a recent application report available from the Semiconductor Division (Transistors) of Standard Telephones and Cables Ltd., of Footscray, Sidcup, Kent. The 38-page report (MK/178) presents the data, mostly in graphic form, needed for the design of small signal amplifiers.

2WW 324 for further details

**Complex transformation ratio measurement** is the title of Technical Bulletin 105 published by North Atlantic Industries Inc. It describes the measurement technique of phase sensitive nulling, which is claimed to have an accuracy of 0.0001% for in-phase and quadrature transformation ratios, and is available in this country from Aveley Electric Ltd., of South Ockendon, Essex.

2WW 325 for further details

A completely revised version of the booklet "**A Guide to Araldite Epoxy Resins**" is now available from CIBA (A.R.L.) Ltd., of Duxford, Cambs. The aim of this booklet, say the publishers, "is to enable the user to compare the various Araldite resin-hardener systems and to select the one that suits his requirements."

2WW 326 for further details

"**9% Nickel Steel for cryogenic structures**" is the title of a recent publication available from the publicity department of the International Nickel Company (Mond) Ltd., 20 Albert Embankment, London, S.E.1. It includes details of a ferritic steel that has excellent strength and resistance to brittle fracture at temperatures down to  $-200^\circ C$ .

2WW 327 for further details

A "**Stock Catalogue**" listing the products available from the recently formed electronic services division of Standard Telephones and Cables Ltd. is now available from the division's headquarters in Edinburgh Way, Harlow, Essex. This 67-page publication (MG/101) is well illustrated and includes a wide range of components—from avalanche rectifiers and coaxial cables to transistors and transformers—integrated circuits, mechanical systems for component packaging, printed-circuit board packaging and racking, etc.

2WW 328 for further details

**Transistor Do's and Dont's**.—Newmarket Transistors Ltd., of Exning Road, Newmarket, Suffolk, have produced a wall chart giving general hints on how to avoid damage to transistors. This chart, which is obtainable on request, should serve to be a permanent reminder of what to do when handling, storing, installing and removing transistors.

2WW 329 for further details

# HF COMMUNICATIONS

## PROPAGATION AS A CONTROLLING FACTOR

By G. MILLINGTON,\* M.A., B.Sc., M.I.E.E.

**T**HERE are two factors which spur the designers of equipment to develop new techniques. One is economic—the reduction of the capital cost of equipment and the cost of its operation and maintenance—and the other is the search for better performance. In HF communication, the second factor includes all those measures taken to overcome the limitations imposed by the propagation medium. This factor will be the main concern of this article and, in discussing it, it is useful to go back to the beginning of the story and to consider how the art of HF communication came into being, with the attendant difficulties that were subsequently met.

It is a matter of history that the part of the radio-frequency spectrum now known as the HF band was originally allotted to the amateurs, as it was thought from the behaviour of the ionosphere at lower frequencies that propagation would be restricted to the very limited ground-wave ranges. The pioneer research of Guglielmo Marconi, together with the information obtained from long-distance contacts made by amateurs, revealed that world-wide communication on high frequencies was in fact possible, and the explanation was later found in the discovery of the F layer and in the elucidation of its properties as a propagation medium.

It is interesting to note that whenever a new mode of propagation has been discovered it has always been found to have limitations which restrict its full use. For example, the introduction of the beam system to replace the projected Empire chain of long-wave transmitters was a bold move in the light of what is now known of ionospheric propagation, even though it had considerable advantages over cables and low-frequency communications as they then existed. But even from the beginning, it was realized that the propagation conditions depended on the time of day, posing the problem of the best frequency to use at a given time for a particular circuit. A connection with solar activity was confirmed by the finding of seasonal and annual effects and more especially by the close relation with the sun-spot cycle. There has thus always been the need to predict future conditions in order to plan ahead the frequencies to be used.

The early knowledge of the world-wide distribution of ionization was based on the experience gained from the behaviour of the beam circuits, supplemented by the use of charts derived theoretically from a simple idealized model of the formation of the ionosphere by solar radiation. Later, there followed the measurement of vertical-incidence critical frequencies, using pulse techniques, at a number of stations at various places in the world, from which the propagation characteristics at oblique-incidence could be deduced by considering the ray paths between the transmitter and the receiver. It also came to be realized that the lower limit of usable frequency was set mainly by the absorption of the wave on its passage through the lower regions of the ionosphere.

It was soon found that long-distance circuits were subject to interruption due to periods of high absorption, especially in the auroral regions, associated with disturbances on the sun. Moreover, the signals were charac-

terized by fading and distortion produced by the interference of waves arriving by different paths, due either to multipath propagation, when several orders of reflection were present simultaneously, or to double refraction associated with the earth's magnetic field whereby a ray entering the ionosphere is split into two rays with different characteristics. A further complication arose from interference caused by other stations and by atmospheric or radio noise originating in lightning flashes and travelling by ionospheric reflection from the thunderstorm areas in the tropical regions.

The development of HF communications has thus been a contest between the ionosphere and the engineer, the one placing obstacles in the way of achieving a perfect communication system and the other overcoming them by technical development, stimulated by an ever-increasing knowledge of his adversary.

## Prediction of Ionospheric Conditions

In order that the best use may be made of the available frequencies, it is necessary to know the distribution of ionization over the earth at any time and to be able to predict well ahead for planning purposes. During the International Geophysical Year (I.G.Y.) 1957-1958 a vast amount of ionospheric data was obtained from the many new sounding stations which were put into operation, some of which have been retained. Important new information is now available<sup>(1)</sup> about the structure of the ionosphere in the polar regions and in the vicinity of the magnetic equator, although there are still large gaps in the world-wide coverage, especially over the oceans.

Whereas the I.G.Y. was chosen to include a period of maximum sun-spot activity the current (1964/65) International Quiet Sun Years (I.Q.S.Y.) cover the period of the sun-spot minimum. With the greatly increased data now available, new methods of prediction are being introduced using electronic computers. Work is continuing on the difficult task of predicting the trend of the sun-spot cycle and the onset of ionospheric storms. Charts have now been produced giving maximum usable frequencies for sun-spot maximum and minimum conditions respectively, from which it is intended that values for intermediate conditions can be found when the sun-spot number becomes available.

It is now known that the earth's magnetic field plays a major part in controlling the distribution of ionization over the earth especially in the magnetic polar and equatorial regions. The Canadian satellite, *Alouette*, in its nearly circular orbit at about 1,000 km above the earth, has proved outstandingly successful as a top-side sounder and is greatly increasing the understanding of the structure and formation of the ionosphere<sup>(2)</sup>.

Whereas the maximum usable frequency for a given circuit is practically independent of the radiated power, the lowest usable frequency can be decreased by increasing the power to offset the greater absorption encountered in

\*The Marconi Research Laboratories, Gt. Baddow, Chelmsford, Essex.

the ionosphere. Its determination is thus a problem of estimating signal-to-noise ratios. It is, however, far more difficult to assess field-strengths in long-distance propagation from vertical incidence data than to predict maximum usable frequencies.

From measurements of atmospheric noise made at some of the ionospheric stations throughout the world, charts have been constructed from which the noise level at any place can be found as a function of the time of day and of the year for given frequencies and receiver bandwidths. They are subject to successive revisions as more comprehensive and reliable measurements become available, but the estimation of lowest usable frequencies is now becoming a reasonably satisfactory process.

## Operational Sounding

Although the planning of HF communications on the basis of prediction charts is well established, it is still difficult to anticipate abnormally good or bad propagation conditions. It is a moot point whether it is better to plan for a disturbance that has been predicted but may not materialize, or to cope with difficult conditions when they arise by re-routing traffic.

On the other hand, it is well known that sometimes frequencies well above the predicted value can be used with advantage; this is so especially in the evening hours on routes crossing the equator in the Far East, and generally under conditions where the ionospheric layers have a tilt not taken into account in making the predictions.

There is thus a need for a more direct way of assessing the propagation conditions as they exist over a given path at any moment. Two methods, back-scatter and oblique-incidence sounding, have been developed. The first depends upon a pulsed radar technique using a rotating aerial system and showing on a PPI presentation, by back-scattering from the ionosphere, the areas of the earth's surface being illuminated at the operating frequency<sup>(3)</sup>. The second depends upon the reception at oblique-incidence, over the path under investigation, of pulse transmissions using a sweep-frequency technique made possible by crystal-controlled synchronization of the transmitter and receiver.

Ideally, it should be possible to make continual variations to the frequency being used on a given circuit to keep it close to the maximum usable frequency, as revealed by the oblique-incidence sounder working over the same path; this would alleviate multipath troubles and ensure an increase in field-strength due to focusing at the edge of the skip distance. However, this would probably be impracticable except for some very special military applications. Great interest is nevertheless being taken in the possibility of working circuits at higher frequencies than those predicted for normal conditions, when an oblique-incidence sounder shows that a worthwhile period of operation is expected.

## Fading and Distortion

Great as are the problems of frequency selection in HF communications, the most serious difficulties have arisen through fading and distortion troubles associated with wave interference and time delay effects. It is here especially that the greatest ingenuity has been displayed and where many recent advances have been made.

In so far as much of the trouble has its origin in multipath propagation, due to the existence of several reflection modes, a possible method of attack is to devise an aerial system that receives at any moment only one

mode, ideally the dominant one. Much work has been put into the design of steerable aeriels, and advanced techniques involving electronic switching and computing devices have been developed for steering in both the vertical and horizontal planes<sup>(4)</sup>. It still remains to be seen whether such highly sophisticated systems will be practicable for other than very special uses, and thus become commercial propositions.

The problem of combating the effects of fading and distortion has led to many other techniques now familiar to design engineers, and recent advances have concerned their continued development with the aid of modern methods. They may be summarized as follows:

(a) diversity systems including time, space frequency and polarization diversity, whereby two or more signals fading largely independently are received from the incoming waves from which by suitable circuit arrangements the best available response at any moment can be derived. (Where the signals are intrinsically weak it has been suggested that by correlation techniques a useful discrimination in favour of the wanted intelligence against random noise should be obtainable.)

(b) modulation techniques such as frequency-shift keying and single-sideband operation designed to increase the intelligibility of the received signal when the fading characteristics vary within the range of frequencies involved.

(c) error correcting circuits<sup>(5)</sup> and codes which indicate when errors are present and automatically correct them, or which convey the correct intelligence even when a coded signal has been altered in the process of propagation.

## Conclusion

It is clear that much is being done, where propagation characteristics are concerned, to keep HF communications abreast of modern requirements. Although the above summary of design techniques is not meant to be exhaustive, it does serve to illustrate the way in which the engineer by his ingenuity and skill has faced the challenge presented by the ionosphere, not only in its intrinsic behaviour as a reflector, giving rise to multipath propagation, but more especially on account of its variable and often fickle nature.

It may well be that the ultimate limit is being approached, beyond which no further fundamental advance is possible, but it can be said that the intensive work being carried out, both in improving ionospheric knowledge and in the engineering of communication systems, has ensured that the HF band can play its part in communications for many years to come.

## REFERENCES

- (1) "Some Ionospheric Results obtained during the International Geophysical Year." Proceedings of a Symposium by the U.R.S.I./A.G.I. Committee, Brussels, September 1959. (Elsevier Publishing Company, 1960.)
- (2) E. S. Warren: "Some Preliminary Results of Sounding of the Top Side of the Ionosphere by Radio Pulses from a Satellite," *Nature*, Vol. 197, pp. 637-9 (1963).
- (3) E. D. R. Shearman: "An Investigation of the Usefulness of Back-Scatter Sounding in the Operation of HF Broadcast Services," *Proc. I.E.E.*, Vol. 108, pp. 361-74 (1961).
- (4) D. W. Morris, G. Mitchell, E. J. P. May, C. J. Hughes and D. I. Dalgleish: "An Experimental Multiple-Direction Universally Steerable Aerial System for HF Reception," *Proc. I.E.E.*, Vol. 110, pp. 1569-82 (1963).
- (5) P. R. Keller: "Automatic Error Correction," *W.W.*, Vol. 70, pp. 62 and 118 (1964).



# Point-to-Point Review—1964

THE SUNSPOT MINIMUM IS PAST

By DAVID WILKINSON,\* DIP. TECH. (ENG.), A.M.I.E.E.

**P**ERHAPS the most satisfactory feature of the year, from the HF user's point of view, was the long-awaited sign that the sunspot minimum is past. It now seems certain that the sunspot number will no longer stay steady at around 10, as it did in 1964, but will begin to rise again. Professor M. Waldemeier, of Zurich Observatory, has now confirmed, provisionally, that the sunspot minimum occurred in October.

As was observed in last year's review†, the sunspot pattern over the past few years has followed remarkably closely the pattern of the years preceding the minimum of 1876/8. And 1964 has made this parallel even more striking. However, it would be sad indeed if the poor maximum of 1882 were repeated, as the sunspot number reached only about 75, compared with the phenomenally high value of 200 (smoothed), for the last maximum in 1958. One may seek some consolation in the fact that many attempts have been made to predict the nature of future sunspot cycles (on a much more scientific basis than this), and in most cases they have proved wrong.

In retrospect, circuit working seems to have been much easier than might have been expected. Well-engineered HF telegraph circuits, e.g. London-Bahrain, consistently recorded efficiencies of 98 per cent, even in the winter months. This means that, on a circuit employing error detection and correction, the total lost time is only about 28 minutes per day. During the easier daytime conditions, the lost time averages 30 seconds per hour. This state of affairs must be largely due to the use of more sophisticated radio and telegraph channelling equipment than was available at the previous sunspot minimum, in 1954.

No Dellinger-type fades were observed during the year. M-region storms, which tend to follow a 27-day cycle, were much less marked than in 1963. The last two months of 1964 were, magnetically, very quiet indeed.

The influence of sporadic E was again marked. Many circuits, e.g. London-Nairobi, operated consistently throughout the month on, or above, the median MUF. Sporadic E has thus considerably extended the available HF spectrum, during the year, and has helped to ease difficulties due to QRM.

The year was marked by considerable activity in the satellite field. Television pictures of the Olympic

Games were carried from Tokyo to the United States via the Syncom III satellite. On occasions, these pictures were then simultaneously relayed across the Atlantic by the Relay II satellite. Much work has been going on behind the scenes in order that all will be ready for the launch, early in 1965, of HS303 (colloquially known as "Early Bird"), which will be the first satellite to be used for carrying commercial traffic.

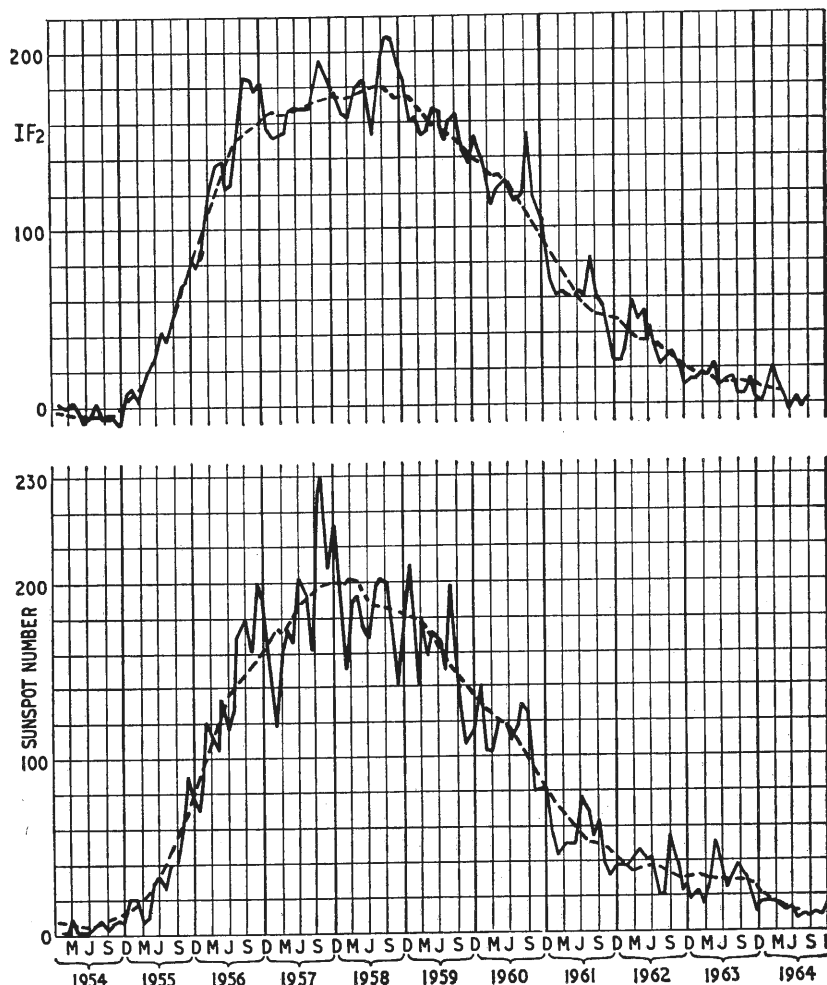

The monthly and smoothed values of the ionosphere index (IF2) and the sunspot number for the past eleven years.

\*Cable & Wireless Ltd.  
†W.W. February 1964, p. 87

## Engineers All

**A** CORRESPONDENT, athirst for information to the point of omitting to stamp his letter, appeals for a clarification of the multitudinous categories of electronics engineer, the services of whom are so seductively sought on the advertisement pages of this journal and our More Important Newspapers. "What do they all do?" he asks.

This is a very difficult question to answer. Don't misunderstand me; I don't mean that engineers are bone idle. On the contrary, the engineer is the very backbone of the industry; the man who, by keeping his shoulder to the wheel, his nose to the grindstone and his back to the wall (and believe me, it's incredibly difficult to work in that posture) has made electronics what it is today. Whatever that may

No—it's the great diversity within the fraternity which creates the problem. Research; Project; Development; Processing; Sales; Design; System Performance. Engineers all. You name them; the industry's got them, in roughly the same numerical strength as the sand on the sea-shore. I can only deal with one or two.

### Physicists

Just off the end of the scale (and I will not say at which end) is the physicist. He is a man who sees an oak door as a collection of tiny atoms with lots of space between them and accordingly tries to walk straight through. Anyone who uses the unscientific method of first opening the door is regarded by the physicist as not with it.

Ministries and managements have never quite known why they employ physicists, but it seems to be the done thing, so they do it. Largely to keep him out of their hair they contain him in a luxurious air-conditioned padded cell called a laboratory and give him lots of pretty materials and very expensive toys to play with, and let him be. From then on he operates rather like a battery hen, getting bodily sustenance (caviare and chips) and mental sustenance (*The Times* and *The Daily Worker*) pushed in\*, in return for which he lays an occasional egg in the form of a treatise on "The Enhancement of Eigen Functions by Raman Scattering from the Surface of Beer" or something equally profound. These are eventually published by a learned journal in the pious hope that it may make sense to somebody somewhere. This battery business goes on until the day when he gets a shade too familiar with his equipment and electrocutes himself. His wife is thereafter referred to as the widow of a genius.

The research engineer *par excellence* is easily identified by reason of (a) the fluffy little white cloud which permanently envelops his head and (b) by the way in which his feet ever-so-slightly do not touch the ground. These circumstances make it difficult for him to see where he is going, and impossible to get there anyway, but this is not terribly important as even if he could and did (if you see what I mean), the Management would find a hundred excellent reasons for returning him to square one again.

Entry to the profession is by stringent examination. The candidate is given (a) a domestic radio (b) a mains plug and (c) a wall socket; he must then satisfy the examining Authority that he is quite incapable of connecting the three together. Status is allocated in ratio to the number of fuses blown in the exercise, the top score being the tripping of all circuit breakers and the initiation of a major fire at Battersea power station, but few candidates attain to this distinction.

The common or garden research engineer (house fuse only,

and a degree at one of the new Redbricks) is not afforded the luxurious surroundings of the physicist, but is not on the whole ill-treated. His habitat is a kind of glass cage, shared by others of the species. Here he is plentifully supplied with sealing-wax, chewing gum, bootlaces, string, and a 1912 textbook, and brusquely told to get weaving on the design of a 1000-terawatt walkie-talkie which is wanted yesterday on a Ministry contract carrying a heavy penalty clause.

The zealot will immediately get down to it, but the really ambitious lad sets about getting himself recognized as an Authority. The first step is to enrol on an extra-mural course on Incomprehensibility, after which he contributes papers like mad to his favourite Learned Society. Such a paper starts off chattily with something simple like:

$$[S] - \left( O_{37} b^{-9} E + \frac{1}{ThE_8} + \frac{\omega}{P_{11}} \right) \left( H_0 + b^{-5} E + \left( \frac{1}{6^{-5} y} \right) \right) - \left( \frac{\omega}{O_{37} P^2} \right) \left( \frac{E_{72}}{n_{11} L^3} \right)$$

and then goes on to show in 14,000 multi-syllabic words that the output stage of an uncooled 1000-terawatt transmitter on peak power is liable to get warmish.

At the end of ten years on the 1,000-terawatt project, the now fully fledged research engineer emerges with an experimental model of an electronic mousetrap. There are only three small snags to be ironed out, namely that (a) it requires a megawatt of input, (b) only very short-sighted mice are catered for, and (c) it doesn't work. The research engineer is then promoted to Group Leader and passes the entire project, chewing gum, bootlaces and all, to the development engineer.

### In Mid-Field

The development engineer, like Ishmael, feels the hand of every man against him. This is not schizophrenia, it is fact. He is the hapless target midway between the two irresistible projectiles of Research (which devoutly believes he has a magic wand which makes things work) and Management (which harbours the foolish notion that profits should be made).

The development engineer is trained from the cradle with a diurnal massage with emery cloth to toughen his hide. At the age of six he is working his way through the more depressing Russian novels, and by adolescence is a Grade 1 Existentialist. At the age of 35, even the ulcers on his ulcers have contracted ulcers.

His vocabulary is limited in the extreme, being confined to the one word "Impossible!" This is not just an English characteristic; it is international. I once knew an Armenian development engineer, and with him it was "Not bloody doings!" but the sentiment is the same.

The development engineer accepts the electronic mousetrap from Research, puts a hammer into it and starts again, using left-over circuits from other projects. At the end of six fruitful years his labours are presented to Management. The electronic mousetrap is now an edifice rather like a drunken cinema organ in steel and phosphor-bronze. Its specification has been improved out of all recognition; it now not only allegedly catches mice, but elderly rabbits as well, and also has a computer-operated device for removing stones from horses' hooves. The power consumption has been reduced to a modest 500kW, but at some sacrifice of efficiency, in that the mice must now be not merely myopic but totally blind.

\* He buys his own "Daily Mirror" of course—Ed.

At this point the Ministry orders 500, having been tipped off by MI5 that You-Know-Who are plotting to drop their mice near our Nuclear Establishments with the object of wresting top-secret secrets from resident British mice by plying them with vodka.

The field engineer now takes over, and installs the prototype—in a field, naturally. After six months' trials the only thing which gets caught is the field engineer's girl friend, who—but this is hardly relevant.

When all seems lost the field engineer turns defeat into triumph by installing a non-electronic cat in the middle of the apparatus. Unfortunately, the cat turns out to have Leftish tendencies and annihilates only British mice, but this doesn't matter much, because by now the Ministry has got over that scare and is hot on the track of another one. The remaining 499 electronic mousetraps, which by now are dotted all around the country, are commissioned and then scrapped.

And so, as the sun sinks slowly in the west, we say a reluctant farewell to the field engineer's Chairman, who, with ruin staring him in the face for the past six months, has just stared back harder and treated himself to his fourth executive aircraft. . . .

## Stereo Broadcasting Survey

REFERENCE was made last month to the position of stereo broadcasting in the U.K. and to the B.B.C.'s plans to continue experimental pilot-tone transmissions from Wrotham, Kent, on 91.3 Mc/s while bringing to an end the series of dual-transmitter stereo experiments.

In view of the limited stereo transmissions in this country it may be of interest to summarize the position in other countries as revealed in a world survey prepared by the European Broadcasting Union and published in the *E.B.U. Review (A)* last June. This showed that despite the fact that no decision has been reached regarding a European standard the number of stations in the area radiating pilot-tone transmissions continues to grow. The biggest concentration is in Germany. In West Berlin there are three transmitters regularly radiating stereo. There are also four transmitters of Westdeutscher Rundfunk, two of Norddeutscher R. and another of Saarlandischer R. regularly using the pilot-tone system. Early in 1965 Hessischer Rundfunk is to introduce stereo from five of its stations. A few months ago Italy began stereo transmissions from four new transmitters and Austria introduced experimental transmissions from one station.

For some time until last September the French broadcasting authority had been using a system employing a 70 kc/s amplitude-modulated subcarrier but this is now replaced by pilot-tone transmissions from two stations. The Netherlands has used the pilot-tone system at its Lopik station for the past 18 months.

The review reveals that in March 1964 there were 295 stations in the U.S.A. regularly broadcasting stereo programmes—this is more than 25% of the country's f.m. stations. There were also a further 67 stations equipped for stereo but not then radiating it. In Canada 16 private broadcasting stations have regular stereo programmes and the Canadian Broadcasting Corporation plans to introduce it in 1966.

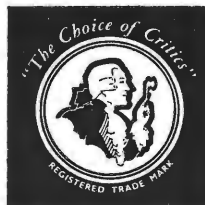

# THE HOUSE OF BULGIN AT YOUR SERVICE

## ENGRAVED SIGNAL LAMPS SECRET until **LIT**



List No. D.908/M/SS/Colour/Legend

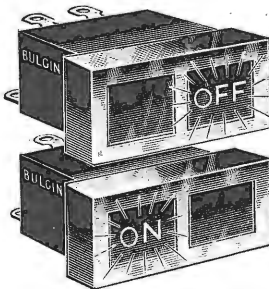

List No. D.722/M/SS/Colour/Legend/Colour/Legend



List No. D.120/M/SS/Colour/Legend/Socket

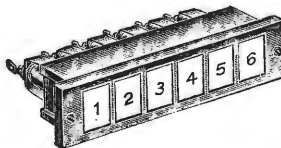

List No. D.370/6

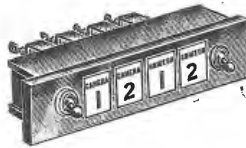

List No. D.372/25/2L

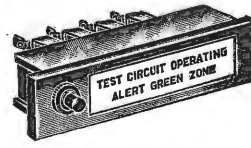

List No. D.872/15/1L

Pioneers of Engraved Signal Lamps in Great Britain and still leading the field. These illustrations show only a small section of our vast range of over 250 types.

For fully illustrated information send for a copy of the leaflet mentioned below.

- ★ ONE MESSAGE OR MORE
- ★ IN ANY COLOUR
- ★ ENGRAVED TO ORDER
- ★ IN ANY LANGUAGE
- ★ BLACK MOULDED BODIES
- ★ STAINLESS STEEL BEZELS
- ★ 60°C MAXIMUM TEMPERATURE
- ★ SEND FOR LEAFLET 1512/C FREE ON APPLICATION

MANUFACTURERS AND SUPPLIERS OF RADIO AND ELECTRONIC COMPONENTS TO

ADMIRALTY	MINISTRY OF WORKS	B.B.C.
WAR OFFICE	MINISTRY OF AVIATION	G.P.O.
AIR MINISTRY	MINISTRY OF SUPPLY	I.T.A.
HOME OFFICE	RESEARCH ESTABLISHMENTS	N.P.L.
CROWN AGENTS	U.K.A.E.A.	D.S.I.R.

A. F. BULGIN & CO. LTD.,  
Bye Pass Rd., Barking, Essex.  
Tel: RIPpleway 5588 (12 lines)

2WW-150 FOR FURTHER DETAILS.

# FEBRUARY MEETINGS

*Tickets are required for some meetings: readers are advised, therefore, to communicate with the secretary of the society concerned*

## LONDON

3rd. B.K.S.T.S.—“Television sound techniques” by E. G. M. Alkin at 7.30 at the Central Office of Information, Hercules Road, S.E.1.

5th. Television Soc.—“The N.T.S.C. colour television system using additional reference transmission (A.R.T.)” by Dr. N. Mayer at 7.0 at I.T.A., 70 Brompton Road, S.W.3.

10th. I.E.E.—“Radar—present position and future trends” by Dr. E. V. D. Glazier at 5.30 at Savoy Place, W.C.2.

10th. I.E.R.E. & I.E.E.—Discussion on “Safety of operating theatre equipment” at 6.0 at 9 Bedford Square, W.C.1.

11th. I.E.E.—Discussion on “The electrometer amplifier: its design and applications” at 5.30 at Savoy Place, W.C.2.

11th. Radar and Electronics Assoc.—“Civil air traffic control” by J. N. Toseland at 7.0 at the Royal Society of Arts, John Adam Street, Adelphi, W.C.2.

15th. I.E.E.—Colloquium on “Design of solid-state power supplies” at 3.0 at Savoy Place, W.C.2.

17th. I.E.E.—Faraday lecture on “Colour television” by F. C. McLean at 5.30 at the Central Hall, Westminster, S.W.1.

17th. I.E.R.E.—“Transistorized equipment designed for television exploitation of radar information” by R. Aste at 6.0 at 9 Bedford Square, W.C.1.

18th. I.E.E. & I.E.R.E.—Colloquium on “Automatic aids to machine fault finding” at 2.30 at Savoy Place, W.C.2.

18th. Television Soc.—Discussion on “Six months’ experience with BBC-2” at 7.0 at I.T.A., 70 Brompton Road, S.W.3.

22nd. I.E.E.—“Layer structure of the troposphere” by Dr. J. A. Saxton, J. A. Lane, R. W. Meadows and Dr. P. A. Matthews at 5.30 at Savoy Place, W.C.2.

23rd. I.E.E.—Discussion on “What is systems engineering?” at 5.30 at Savoy Place, W.C.2.

24th. I.E.R.E.—“A low-cost video tape recorder for professional applications” at 6.0 at the London School of Hygiene and Tropical Medicine, Keppel Street, W.C.1.

24th. B.K.S.T.S.—“Acoustics and plucked string instruments” by Dr. W. H. George at 7.30 at the Central Office of Information, Hercules Road, Westminster Bridge Road, S.E.1.

25th. S.E.R.T.—“Up and down standards—conversion of television signals” by R. F. Vigurs at 7.15 at the London School of Hygiene and Tropical Medicine, Keppel Street, W.C.1.

## ABERDEEN

24th. I.E.E.—Discussion on “Television as a teaching aid” at 7.30 at Robert Gordons Technical College.

## BIRMINGHAM

10th. I.E.E.—“Microminiaturization in the electronic industry” by G. W. A. Dummer at 6.15 at the College of Advanced Technology, Gosta Green.

17th. Television Soc.—“Film in television—the technical problems” by G. Salter at 7.0 at the College of Advanced Technology, Gosta Green.

22nd. I.E.E.—“Management problems in the planning of electronic engineering projects” by W. T. Brown and G. S. Kermack at 6.0 at the James Watt Memorial Institute.

23rd. S.E.R.T.—“Some aspects of 625-line receivers” at 7.15 at the College of Advanced Technology, Gosta Green.

## BOLTON

11th. I.E.R.E.—“Analogue computing and digital techniques in aviation control systems” at 7.0 at the Technical College.

## BOURNEMOUTH

3rd. I.E.R.E.—“Digital computers in road traffic control” by H. A. Codd at 7.30 at the Municipal College of Technology and Commerce.

## BRIGHTON

24th. I.E.E.—“A microcircuit logic system” by Dr. D. J. Truslove at 6.30 at the College of Technology, Moulescoomb.

## BRISTOL

9th. Television Soc.—“Band IV and V aerials” by a representative of Belling & Lee at 7.30 at the Royal Hotel, College Green.

18th. S.E.R.T.—“Transistors—theory and practice” by R. E. Griffin at 7.30 at the Hawthornes Hotel, Clifton.

22nd. I.E.E.—“Numerical control of machine tools” by D. F. Walker at 6.0 at the S.W.E.B. Headquarters.

24th. I.E.R.E. & R.Ae.Soc.—“Micro-miniaturization” by R. O. R. Chisholm at 7.0 at the University Engineering Laboratories.

## CAMBRIDGE

2nd. I.E.E.—“Fuel cells: a branch of electrochemical engineering” by Dr. A. B. Hart at 6.30 at the College of Arts and Technology.

9th. I.E.E. & I.E.R.E.—“Design aspects of white noise intermodulation test equipment” by H. C. Gribben at 6.30 at the College of Arts and Technology.

## CARDIFF

10th. I.E.R.E.—“Superconductors in Instrumentation” by Dr. D. H. Parkinson at 6.30 at the Welsh College of Advanced Technology.

## DUBLIN

18th. I.E.E.—“Oscillating electromagnetic systems” by Prof. J. C. West at 6.0 at the University.

## EDINBURGH

9th. I.E.E.—“Industrial applications of electro-luminescence” by D. Reaney at 6.0 at the Carlton Hotel.

10th. I.E.R.E.—“Sonar” by Dr. V. G. Welsby at 7.0 at the Department of Natural Philosophy, The University, Drummond Street.

## EVESHAM

26th. I.E.R.E.—“Design aspects of laboratory test instruments” by K. A. Fletcher at 7.0 at the B.B.C. Club, High Street.

## FARNBOROUGH

18th. I.E.R.E.—“Hybrid data processing systems at A.W.R.E.” by E. W. Walker at 7.0 at the Technical College.

## GLASGOW

4th. S.E.R.T.—Technical film show at 7.30 at the Central Halls, Bath Street.

8th. I.E.E.—“Industrial applications of electro-luminescence” by D. Reaney at 6.0 at the University of Strathclyde.

11th. I.E.R.E.—“Sonar” by Dr. V. G. Welsby at 7.0 at the Institution of Engineers and Shipbuilders, 39 Elmbank Crescent.

## LEEDS

2nd. I.E.E.—“Satellite communications” by F. J. D. Taylor at 6.30 at the University.

9th. I.E.E.—Discussion on “The value and purpose of industrial training” at 6.30 at the College of Technology.

## LEICESTER

16th. Television Soc.—“Colour television receiver circuits” by P. L. Mothersole at 7.15 at Vaughan College, St. Nicholas Street.

24th. I.E.R.E.—“Parametric amplifier” by Dr. T. Buckley at 6.30 at the University.

## LIVERPOOL

8th. I.E.E.—“Uses of superconductivity” by Dr. A. C. Rose-Innes at 6.30 at the Royal Institution, Colquitt Street.

17th. I.E.R.E.—“Airborne navigational aids” by Dr. T. Gray at 7.30 at the Walker Art Gallery.

## MANCHESTER

16th. I.E.E.—“A traffic simulator” by Dr. F. G. Heath at 6.15 at the College of Science and Technology.

## MIDDLESBROUGH

3rd. I.E.E.—“Stereo-phonetic broadcasting systems” by Dr. G. J. Phillips at 6.30 at Cleveland Scientific Institution.

## NEWCASTLE UPON TYNE

10th. I.E.R.E.—“Electronic control systems in coal mining” by G. M. Rendall at 6.0 at the Institute of Mining and Mechanical Engineers, Westgate Road.

## PLYMOUTH

3rd. Television Soc.—“The I.T.A.—its constitution and operation” by W. A. C. Collingwood at 7.30 at the studios of Westward Television.

## SOUTHAMPTON

23rd. I.E.E. & I.E.R.E.—“Space-charge dielectric devices” by Dr. G. T. Wright at 6.30 at the University.

## SWANSEA

11th. I.E.E.—“The amplitude sampling of speech signals” by Dr. V. J. Phillips at 6.0 at the Engineering Dept. University College.

## TORQUAY

18th. I.E.E.—“Colour television transmission” by H. V. Sims at 6.30 at the South Devon Technical College.